



Vigilohm

Catalogue 2019
Insulation Monitoring
for Ungrounded Networks



se.com

Life Is On

Schneider
Electric



Green Premium™

Endorsing eco-friendly products in the industry



Green Premium™ Product

Green Premium is the only label that allows you to effectively develop and promote an environmental policy whilst preserving your business efficiency. This ecolabel guarantees compliance with up-to-date environmental regulations, but it does more than this.

Over 75% of Schneider Electric manufactured products have been awarded the Green Premium ecolabel



Discover what we mean by green ...

Check your products!

Schneider Electric's Green Premium ecolabel is committed to offering transparency, by disclosing extensive and reliable information related to the environmental impact of its products:

RoHS

Schneider Electric products are subject to RoHS requirements at a worldwide level, even for the many products that are not required to comply with the terms of the regulation. Compliance certificates are available for products that fulfil the criteria of this European initiative, which aims to eliminate hazardous substances.

REACH

Schneider Electric applies the strict REACH regulation on its products at a worldwide level, and discloses extensive information concerning the presence of SVHC (Substances of Very High Concern) in all of its products.

PEP: Product Environmental Profile

Schneider Electric publishes complete set of environmental data, including carbon footprint and energy consumption data for each of the lifecycle phases on all of its products, in compliance with the ISO 14025 PEP ecopassport program. PEP is especially useful for monitoring, controlling, saving energy, and/or reducing carbon emissions.

EoLI: End of Life Instructions

Available at the click of a button, these instructions provide:

- Recyclability rates for Schneider Electric products.
- Guidance to mitigate personnel hazards during the dismantling of products and before recycling operations.
- Parts identification for recycling or for selective treatment, to mitigate environmental hazards/ incompatibility with standard recycling processes.

Table of contents

Overview

Ensuring continuity of service.....	6
Ungrounded earthing system.....	7
Insulation Monitoring Devices for Ungrounded Networks	8
An efficient solution that adapts to your needs.....	9
Communicating solutions for improved reliability and maintenance	12
Application	
Healthcare.....	14
Industry	17
Water and Waste Water	19
Infrastructure and Transportation	20
Utilities	21
Photovoltaic.....	22
Marine	24
Insulation Monitoring of Off-Line Equipment	26
Harsh Environment	27
Medium Voltage Ungrounded Networks.....	28
DC Networks.....	29
Selection Guide.....	30
Range Overview - Industrial Networks.....	32
Range Overview - Healthcare	33

Product datasheets

Vigilohm IM9-OL.....	35
Vigilohm IM9.....	37
Vigilohm IM10 and IM20.....	39
Vigilohm IM10-H, IM15H, IM20-H.....	43
Vigilohm IM400 / IM400L / IM400C.....	47
Vigilohm IM400THR / IM400LTHR.....	51
Vigilohm IFL12 / IFL12L.....	55
Vigilohm IFL12C.....	59
Vigilohm IFL12MC / LMC / MCT / LMCT.....	63
Vigilohm IFL12H.....	67
Vigilohm Mobile Fault Location - XGR, XRM and Probes.....	71
Vigilohm Toroids - Earth Leakage Current Detectors.....	75
Vigilohm HRP (Hospital Remote Panel).....	80
Vigilohm OTD (Operating Theater Display).....	82
Vigilohm Voltage Adaptors - IM20-1700, IM400-1700, IM400-1700C, PHT1000 and IM400VA2.....	85
Vigilohm ZX Plate Earthing Impedance.....	87
Vigilohm P1N Plate Ground Adaptor.....	88
Vigilohm Cardew C Surge Limiter.....	89
Vigilohm Transformers - Europe.....	91
Vigilohm Transformers - Asia.....	93



Overview



Insulation Monitoring



Ensuring continuity of service in the event of an insulation fault

Continuity of service is an essential operational requirement for power networks. The installation must also comply with specific rules to protect people and property.

These safety requirements involve the use of protective devices which operate when there is a risk that could cause the network to become partially unavailable.

The consequences can be significant:

- Total or partial stopping of the process.
- Partial or total loss of production.

An IT ("isolated from earth") earthing system, also called ungrounded earthing system, allows to maintain continuity of service on the installation in case of insulation fault.

What do the standards say ?

The IT earthing system is described in several standards:

- IEC 60364-4-41 Electrical installation in buildings:
 - protection for safety,
 - protection against electric shock.
- IEC 60364-7-710 - Requirements for special installations or locations
 - Medical locations.
- IEC 61557-8 Insulation monitoring devices for IT earthing systems.
- IEC 61557-9 Equipment for insulation fault location in IT earthing systems.

These standards clearly state that, with the IT earthing system, the installation must be isolated from earth or connected to earth through a sufficiently high impedance.

In the event of only one ground or earth fault, the fault current is very low and interruption is unnecessary. Since a second fault would cause a circuit breaker to trip, an insulation monitoring device (IMD) is required to indicate an initial fault.

This device must activate an audible and/or visual signal.

Vigilohm offer complies with international IEC standards.



Ungrounded earthing system – IT system

In an IT earthing system, the neutral of the transformer's secondary is not connected to earth, and the load casing is connected to earth. In the event of an insulation fault, current cannot loop via the transformer's neutral:

- No dangerous contact voltage when touching metal parts.
- Very low fault currents.

Therefore, an IT earthing system guarantees the best continuity of service.

When done in the state of the art, the installation can operate without endangering people and equipment even in the presence of an initial insulation fault.

As a result, protective devices are not triggered. However, the faulty circuit must be detected and repaired before a second fault occurs because a second fault would cause a short circuit between phases and trigger protective devices.

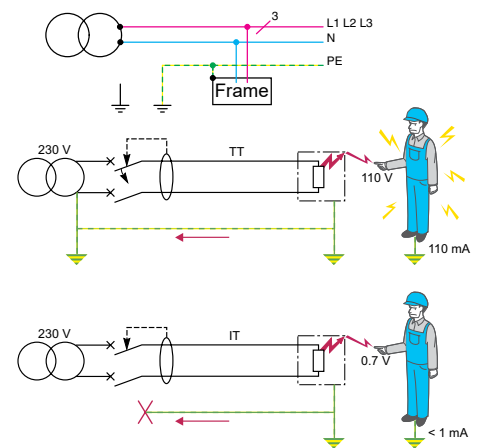

Insulation Monitoring Devices for Ungrounded Networks

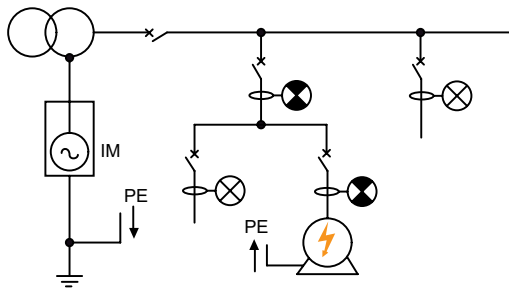

The Insulation Monitor detects and signals an insulation fault based on the alarm threshold set. It activates an alarm relay that can be connected to a sound or light device. It can also send the alarm via communication.

The solution for ungrounded network insulation monitoring

According to the standards, the monitoring of ungrounded networks with Insulation Monitoring Devices (IMD) is mandatory.

An Insulation Monitor (IM) will detect a first insulation fault between an active conductor and the ground.

An Insulation Monitor (IM) injects DC or low-frequency AC voltage between the network and earth. The resulting current that flows through the IMD is then measured, allowing the calculation of the corresponding insulation value. This principle allows to detect balanced insulation faults too.

Note: in an IT earthing system, a 50Hz insulation fault current is difficult to measure directly, since it loops through the capacitances distributed in the network.

Depending on the device, the IM can:

- Display the insulation resistance value locally
- Display the leakage capacitance value for the monitored network
- Store time-stamped alarms
- Communicate with a supervisor.

Insulation Fault Location

If an insulation fault happens in the ungrounded network, it shall be located and corrected, with minimum disruption of the site.

Finding the fault can be done by doing a sequential opening of the circuit breakers; however this method causes a temporary interruption of power on the feeders.

To avoid this, the use of insulation fault locators is beneficial since it allows to locate the fault automatically while keeping continuity of service on the site.

On networks that include a lot of feeders, the use of fault locators also allows to save time and operation expenses to maintain the network.

Some insulation fault locators also provide measurement of resistance and capacitance per feeder; and a settable alarm threshold per feeder.

This allows an individual monitoring of each feeder; which is interesting as feeders can have very different characteristics from one to another –since they have different length, different types of loads connected.

Insulation Fault Locators are associated to an Insulation Monitor. Their measurement principle is based on the low frequency component injected by the Insulation Monitor. VigiloHM range includes permanent Insulation Fault Locators which are connected to the network through toroids (IFL12 range), as well as a manual insulation fault locator kit (XRM and probes).

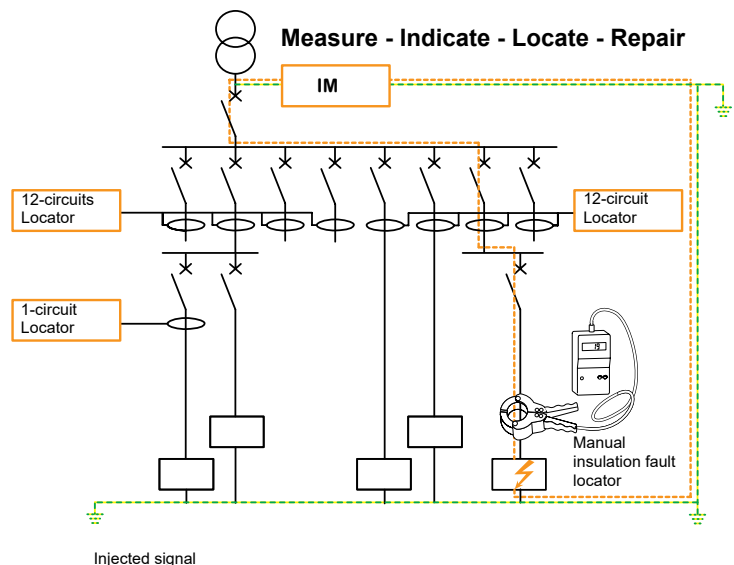

An efficient solution that adapts to your needs

At Schneider Electric, we have been designing insulation monitors for more than 50 years. With this strong experience and understanding of ungrounded networks' specific constraints, we are providing a range of solutions tailored to your needs. While keeping a limited number of references for ease of selection.

Small IT networks or IT islands with no need for automatic insulation fault location

Ease of installation and use

- A transformer creates the IT network (its neutral is not connected to ground).

An Insulation Monitor (IM9, IM10 or IM20) permanently monitors insulation:

- it is generally powered directly by the network it monitors
- it is connected to neutral or to one phase and to the ground
- its main setting to configure is the alarm threshold
- its relay output will report the alarm.

These Insulation Monitors are available in both Multi 9 (DIN rail) and flush-mount formats. Further options depending on model include:

- display of network Resistance in real time
- display of network leakage Capacitance in real time
- Modbus RS485 communication
- Alarm log, to keep an history of the insulation alarms

Note: IM9 should only be used on purely AC networks (with no existing DC component). Otherwise; IM10 or IM20 should be used.

IT networks requiring automatic insulation fault location (basic solution)

Automatic identification of the faulty feeder

- The Insulation Monitor IM400 permanently monitors network insulation (global value of resistance to ground and leakage capacitance), and will detect an insulation fault.
- The Insulation Fault Locators IFL12 or IFL12C report which is the faulty feeder.
- In addition, the manual fault location kit (XRM) can be used to locate exactly the insulation fault cause.
- No wired connection is needed between the Insulation Monitor and the Insulation Fault Locators.
- The number of Insulation Fault Locators is not limited.
- IM400 and IFL12C support Modbus RS485 communication, allowing to send insulation monitoring information to a supervision. This allows to greatly facilitate the prevention and the resolution of insulation fault situations.

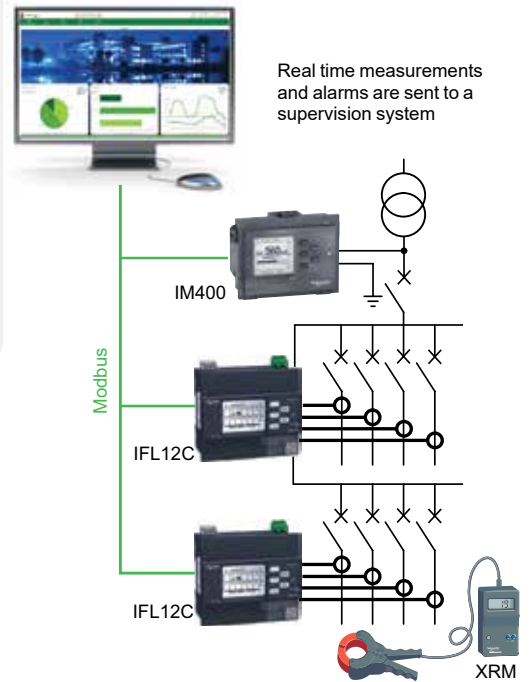
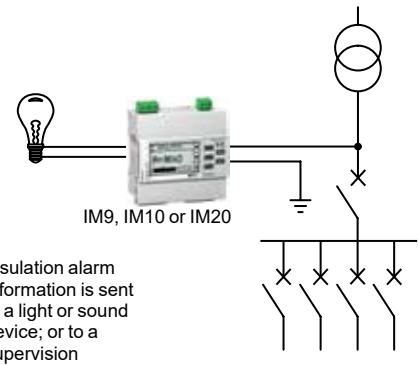

Benefits

- No wired connection is required between the Insulation Monitor and the Insulation Fault Locators:
 - The IFLs can be located at any distance further down the network.
 - No limitation regarding the number of IFLs that can be installed to monitor the network.
- A fully scalable system, that evolves with your installation and needs.

An efficient solution that adapts to your needs

Highly critical IT networks requiring measurements per feeder

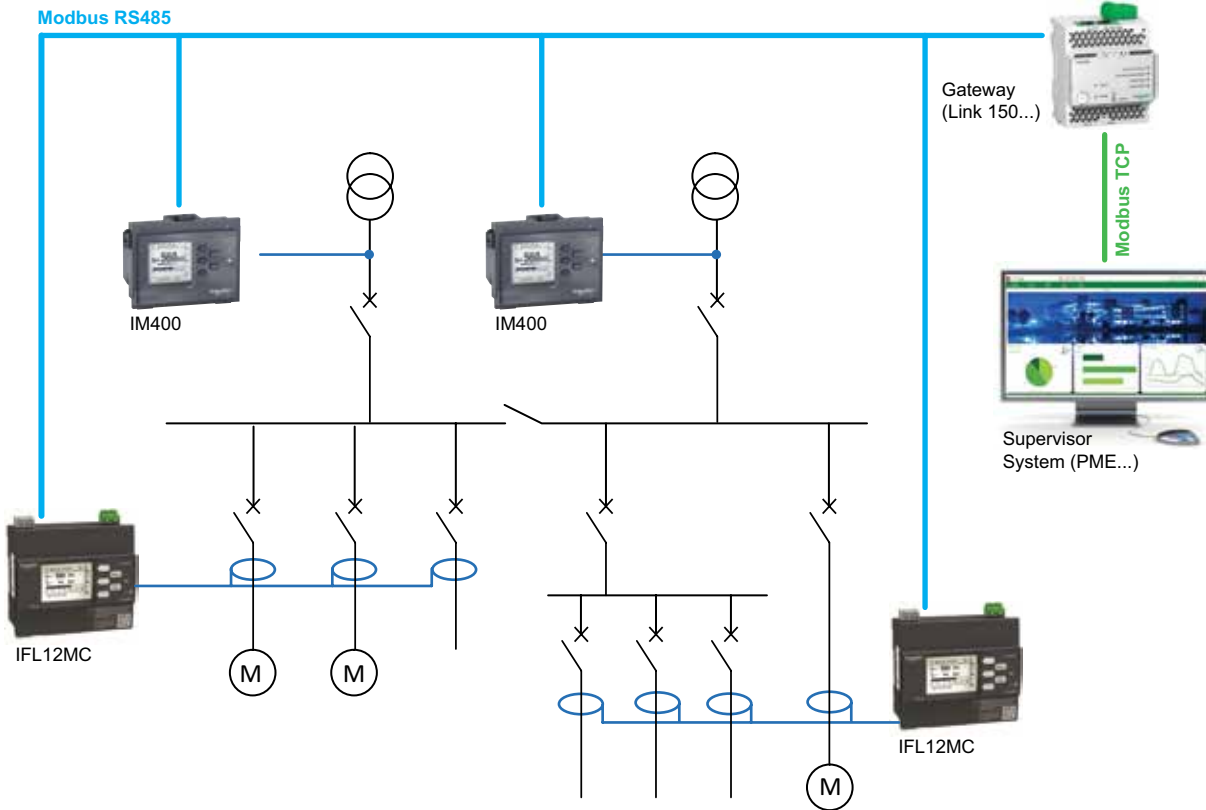

Benefits

Native support of Modbus RS485 by the Insulation Monitor and the Insulation Fault Locators, without needing any additional module.

Gateways such as Link'150 or Com'X510 can be used to connect them in Modbus TCP IP.

Insulation measurement per feeder and settable alarm threshold per feeder

Insulation level from one feeder to another varies a lot depending on the length of cables, the types of loads connected.

This unique solution allows to monitor individually the insulation of each feeder:

- Measure of resistance and leakage capacitance per feeder
- Settable alarm threshold per feeder

This provides a fine tuning of the insulation monitoring of each part of the network, eventually allowing to avoid intempesive alarms; and implement targeted preventive maintenance.



Benefits

Monitoring of leakage capacitance of an ungrounded network

The ability to monitor leakage capacitance of an ungrounded network is essential, since this capacitance can induce the flow of a faulty current no longer negligible in case of first insulation fault. A leakage capacitance too high will cause the IT network to behave like a TT network.

Leakage capacitance is typically due to length of cables or type of loads connected (EMC filters etc).

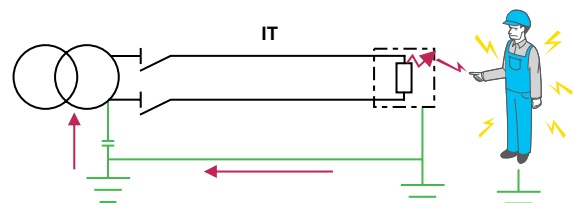

In case of first fault, a faulty current can flow through the leakage capacitance of the IT network.

An efficient solution that adapts to your needs

Vigilohm with Altivar Variable Speed Drives: The Proven and Tested Solution

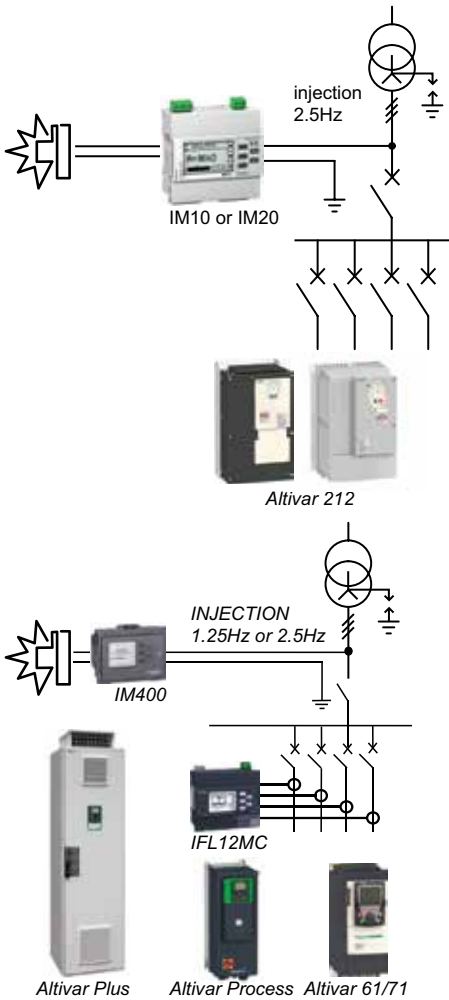

Standalone Variable Speed Drive in Ungrounded Islands

Simple to Commission. Even Simpler to Use

- A transformer creates an ungrounded network.
- A Vigilohm Insulation Monitor (IM10 or IM20) is used to monitor the network insulation:
 - IM powered by the monitored network
 - IM injection is connected to the neutral (or to one phase)
 - IM has one connection to the earth
 - One setting: the alarm threshold (from 0.5kOhm to 500kOhms depending on application)
 - One output: the alarm relay, which can be connected to a visual or audible signal
 - The IM20 also supports Modbus communication.

Multiple Variable Speed Drives in Large Networks

A Solution for Demanding Networks with or without Insulation Fault Location

- IM400 and IFL12MC are suited for demanding networks which include multiple variable speed drives
- Their commissioning is made easy by the limited number of parameters to configure

To know more refer to the brochure: **Vigilohm Insulation Monitoring Devices and Variable Speed Drives**



Vigilohm and Altivar: Better Together with More Advantages



Come Together for the Perfect Solution
 Altivar and Vigilohm development teams collaborated to validate the performance of the two devices when installed together on the same electrical network. The compliance test have been performed with Altivar VSDs, but the results can be applied to other types and brands of VSDs.



With All The Balance You Need
 Altivar VSDs provide thermal and short circuit motor monitoring. Vigilohm IMDs detect and indicate an insulation fault anywhere on the network – upstream, downstream or inside of the VSD (zero-impedance fault downstream is indicated by the VSD).



And All The Support You Want
 The Schneider Electric team of design and maintenance experts brings a wealth of knowledge and specialized expertise to all your electrical distribution and mechatronic command needs.

Communicating solutions for improved reliability and maintenance

Retrieving insulation monitoring data from your network in your supervision system presents many advantages:

- Real time monitoring of resistance and leakage capacitance (global network values and per feeder values)
- Real time monitoring of insulation alarms, with timestamp and indication of the faulty feeder: ease of insulation fault correction for the maintenance team
- Recording of historical insulation values: allows to correlated insulation faults with the start of a process, detect ageing of a part of the installation etc. This analysis allows to reduce the insulation fault occurrence, hence optimize uptime
- Centralization of insulation level from the various ungrounded networks of the site in the supervision.

Vigilohm range includes Insulation Monitors and Insulation Fault Locators with native Modbus RS485 support:

- IM20, IM400, IM400THR, IFL12C, IFL12MC
- IM20-H, IFL12H (healthcare premises).

They can be easily integrated in any supervision system supporting Modbus protocol. Schneider Electric also provides best-in-class solutions, such as:

- Com'X 510 - energy server
- EcoStruxure Power Monitoring Expert (PME) and EcoStruxure PowerSCADA Operation (PSO) – Energy and power monitoring systems.

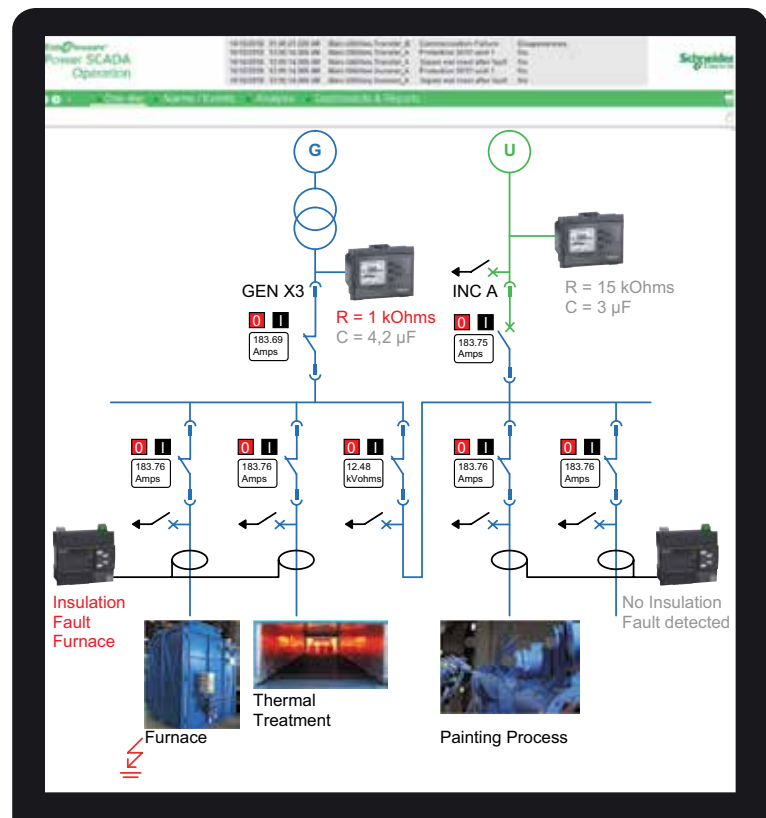

Example of single line diagram including insulation real time monitoring with PSO.

Communicating solutions for improved reliability and maintenance

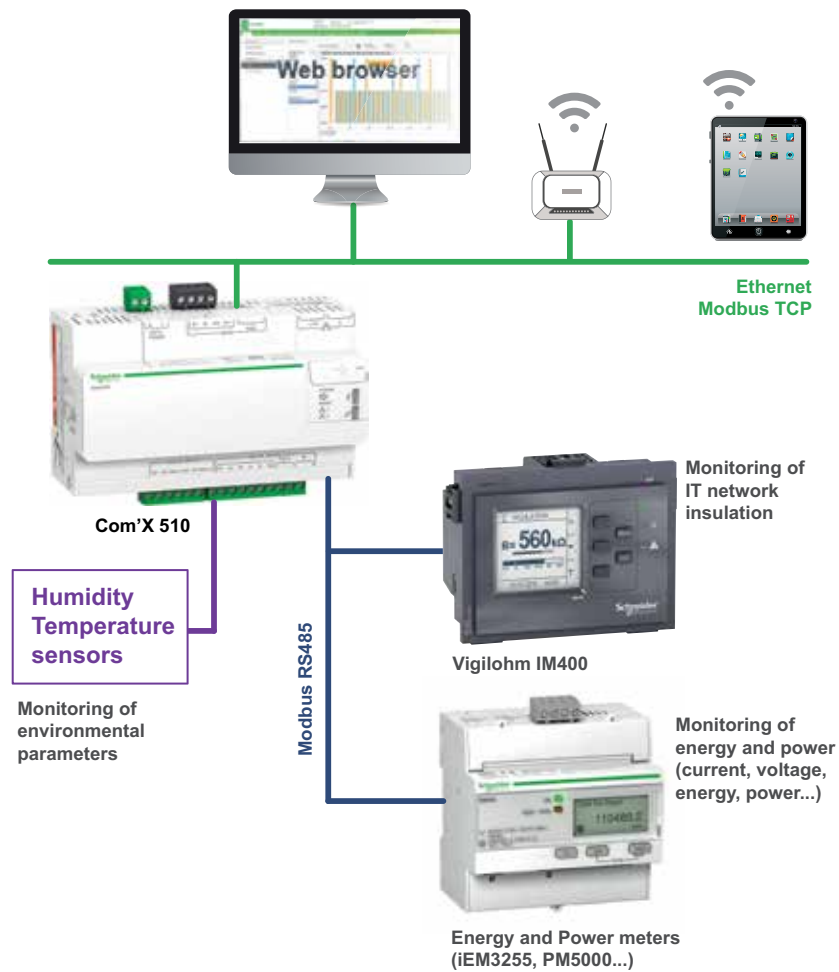

Examples of architectures with Com'X510: a simple monitoring system to retrieve all electrical data.

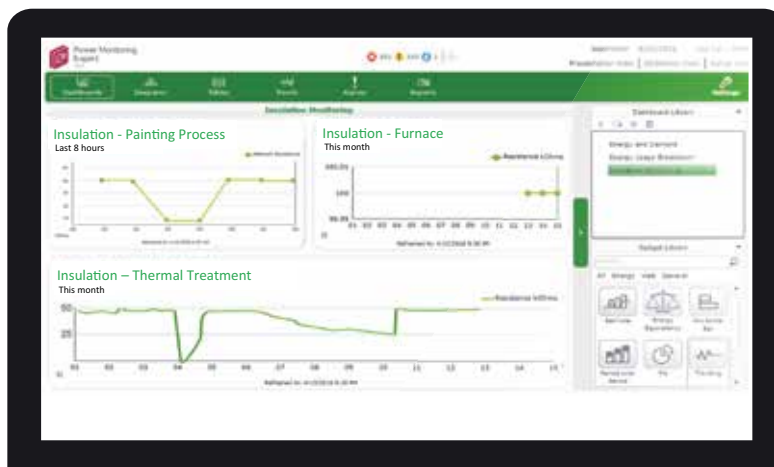

Example of view of historical insulation monitoring data from PME dashboards.

+ **Benefits**
Native support of Vigilohm in PME software: ease of integration and configuration.

Application Healthcare



A fully integrated solution for hospitals and class 2 medical environments

Critical healthcare applications are an essential component of our core mission to protect people and infrastructure through the safe and reliable delivery of energy.

Vigilohm is a key component to implement a safer environment for patients and medical staff in operating theatres, intensive care units and other critical rooms. Everything about Vigilohm is designed to actively contribute to the continuous reduction of operating expenses by providing essential, timely and secure information about electrical system status and diagnostics to key staff, either on site or remotely.

Standards applicable in healthcare environment

- IEC 60364-7-710: Requirements for special installations or locations: Medical locations
- IEC 61557-8: Electrical safety in LV distribution systems up to 1000 VAC and 1500 VDC – Equipment for testing, measuring or monitoring of protective measures – Part 8: Insulation monitoring devices for IT systems
 - Annex A: Medical insulation monitoring devices (MED-IMD) – applicable for Insulation Monitors IM10-H, IM15H, IM20-H
 - Annex B: Monitoring of overload current and over-temperature – applicable for Insulation Monitors IM15H, IM20-H
- IEC 61557-9: Electrical safety in LV distribution systems up to 1000 VAC and 1500 VDC – Equipment for testing, measuring or monitoring of protective measures – Part 9: Equipment for insulation fault location in IT systems
 - Annex A: Equipment for insulation fault location in medical locations – applicable for Insulation Fault Locators IFL12H.

Vigilohm range for healthcare complies with these standards

Some key points required by these standards include:

- In group 2 rooms for medical use, IT grounding should be used for the circuits powering medical electrical equipment and systems for survival and surgical applications. IT should also be implemented for equipment located in the environment of the patient.
 - An audible and visual alarm must be triggered in case of insulation fault to alert medical personnel in the room
 - Monitoring of overload and over temperature for the medical IT transformer is required
 - Where a medical IT system is used to supply multiple rooms or locations, the use of Insulation Fault Locators should be considered
- Regular test of the insulation monitoring system should be performed
- Specific requirements apply to the Insulation Monitor Devices so they can be used in the medical premises, including:
- Value of measuring voltage and current, and internal impedance
 - Ability to trigger an alarm if earth or injection connections are disconnected
 - Values of alarm threshold settable.

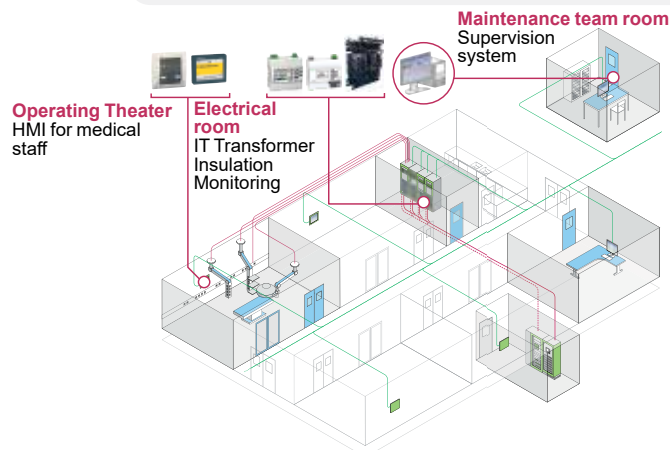

Application Healthcare

A dedicated range of devices for medical premises



Insulation Monitors IM10-H, IM15H, IM20-H

- Monitoring of insulation and signaling of insulation fault, including also (depending on the reference):
- IT transformer monitoring (overload, over temperature)
 - Modbus RS485 communication
 - Timestamped alarm log



Insulation Fault Locators IFL12H

- Location of the faulty feeder
- Settable alarm threshold per feeder
- Customizable name per feeder
- Modbus RS485 communication
- Timestamped alarm log



HMI: HRP, OTD (Operating Theater Display)

- Intuitive interfaces to retrieve information related to insulation fault or electrical fault
- Compatible with operating theater environment
- Option for test of the insulation monitor

Flexible solutions that evolve with your needs

From a basic insulation monitoring solution...

Operating Theater

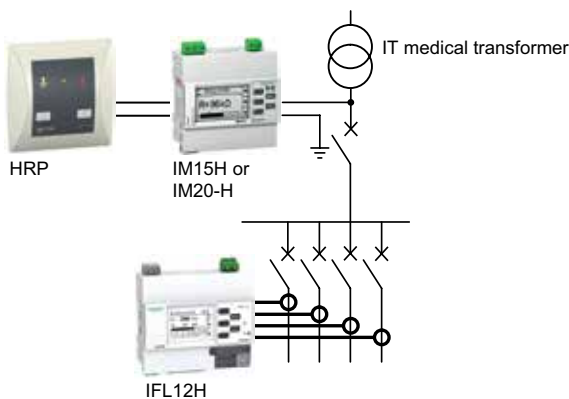

- Medical IT transformers create separate IT networks for each operating theater room
- Vigilohm IM15H or IM20-H monitors the network insulation and the IT transformer
- Any insulation fault or electrical fault (due to transformer overload or overheat) is displayed to the medical staff through the HRP
- Alarm buzzer can be stopped from the HRP
- Insulation fault location will be facilitated by the IFL12H information
- The regular insulation test, required by standards, can be easily initiated by the medical staff through the HRP.

Application Healthcare

... to advanced solutions that include local and remote monitoring

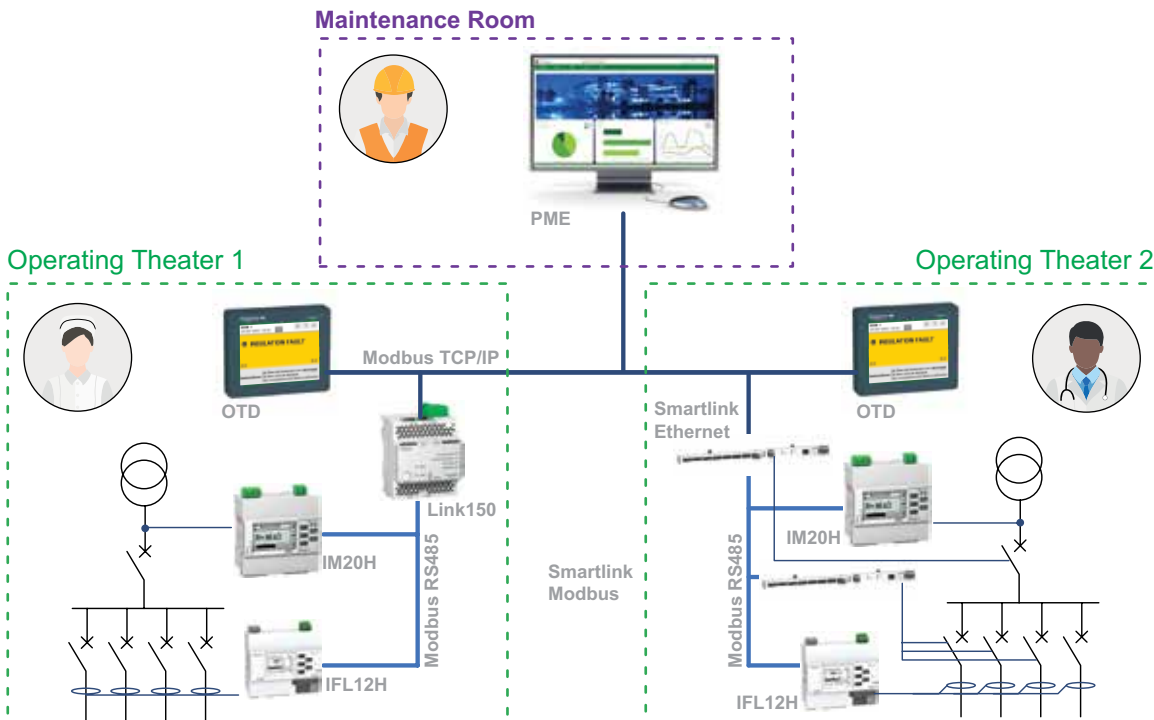

- Medical IT transformers create separate IT networks for each operating theater room
- Vigilohm IM20-H monitors the network insulation and the IT transformer
- Vigilohm IFL12H indicates the faulty feeder in case of insulation fault
- Smartlink (Ethernet and Modbus) monitors the trip of circuit breakers (see example in Operating Theater 2 above)
- Any insulation fault (including its location) or electrical fault (due to transformer overload or overheat or trip of a circuit breaker) is displayed to the medical staff through the OTD display.
- Alarm buzzer can be stopped from the OTD
- The regular insulation test, required by standards, can be easily initiated by the medical staff through the OTD
- Real time data from IM20-H, IFL12H, Smartlink is sent to a supervision system, alerting the electrical maintenance team in case of issue.

Connected products as part of EcoStruxure™ Power

EcoStruxure Power delivers safe, highly available, and energy-efficient electrical distribution systems for low and medium voltage architectures. Our IoT-enabled power management solutions enhance connectivity, real-time operational reliability, and smart analytics for peace of mind and significant financial benefits to businesses of all sizes and maturity levels.

Vigilohm is an integral part of the EcoStruxure Power solutions for healthcare applications, as connected products that can be easily integrated into an edge control such as EcoStruxure Power Monitoring Expert.

Circuit	Impedance (kOhms)
Circuit 01	900 kOhms
Circuit 02	900 kOhms
Circuit 03	900 kOhms
Circuit 04	900 kOhms
Circuit 05	900 kOhms
Circuit 06	900 kOhms
Circuit 07	910 kOhms
Circuit 08	900 kOhms
Circuit 09	900 kOhms
Circuit 10	900 kOhms
Circuit 11	900 kOhms
Circuit 12	900 kOhms



Benefits

Information and alarm messages shown on the OTD can be customized to display specific instructions to the medical staff

Application Industry

Context

Ungrounded networks can be found in industrial sites for critical processes that cannot be stopped unexpectedly. Sites such as cement, steel, glass, paper, aluminium or chemical factories; car manufacturing; food processing etc can use ungrounded networks for their critical processes (furnace, mill, electrolysis vat...)

What is at stake

Depending on the grounding system, an insulation fault will cause protections to trip, causing an unexpected downtime on the site. An important financial loss is at stake in case of unexpected process interruption: aside from production downtime, the raw material involved, which can be costly, may be lost. Some processes are also complex to start again after a downtime. In addition, some sites (such as food silos, chemical installations...) present a risk of fire and explosion, so are sensitive to the circulation of high faulty currents. The use of ungrounded networks, together with an insulation monitor, allows to mitigate these challenges.

What are the constraints from the installation

Industrial sites have several constraints to take into consideration.

- They include disturbing loads such as variable speed drives, or disturbing processes generating harmonics.
- Sites may be ageing, having an insulation level that deteriorates with time.
- IT networks may be quite large with a lot of feeders.
- Technical team on site needs tools to ease the maintenance and the correction of insulation faults.

Vigilohm solution

From the simplest solution with IM10, to the most advanced with IM400 and IFL fault locators, Vigilohm range can meet the requirements.

- Vigilohm products have been tested with variable speed drives.
- Fast response time and recording of intermittent insulation faults, allow correlation of faults with start of a specific load or process
- Communicating products when there is an existing supervision system will facilitate the maintenance on site.
- On industrial sites with harsh environments, the conformally coated version of products is an option.
- IM9-OL can be used for off line insulation monitoring of critical motors.



Application Industry

Case study: Manufacturer of construction equipment

Manufacturing processes of the machines are critical and cannot be stopped unexpectedly, as it would generate important financial losses. Ungrounded networks, monitored by IM400, allow to keep the processes running even in case of an insulation fault.

IFL12MC locators provide insulation measurements and individual alarm threshold per feeder; allowing to fine tune the insulation monitoring according to each process characteristics, and to ease the fault correction. Insulation monitoring and alarming are centralized in a supervision system. Any abnormal insulation decrease is detected and results in maintenance actions. Timestamped alarms allow to correlate the fault with the start of a process or a machine, and to perform post-incident analysis.

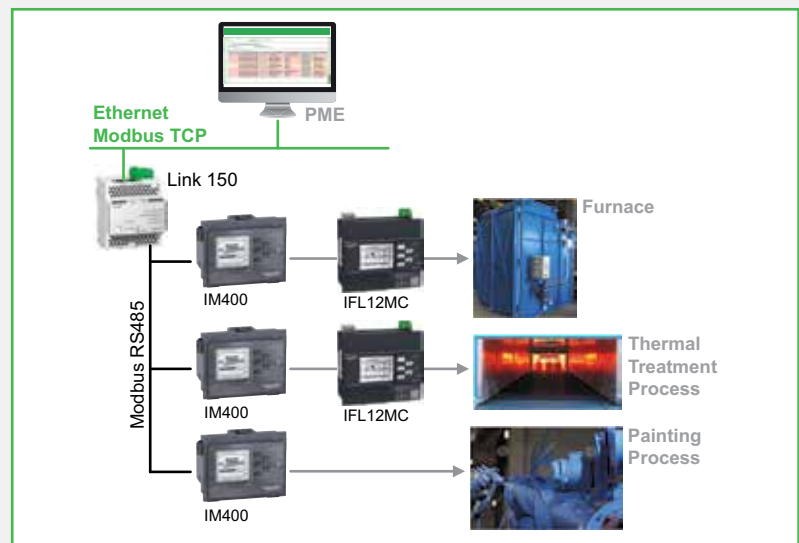

Case study: Manufacturer of PVC floor

This customer uses ungrounded networks to optimize the maintenance scheduling.

The site has approximately 20 IT islands that mainly supply variable-speed drives.

The IT earthing system is chosen, not in relation to a continuous process, but to simplify maintenance. In a TN earthing system, a fault would trip a circuit breaker, and the maintenance team would have to intervene immediately. This would involve a qualified technician being permanently available. In an IT earthing system, a fault that occurs during the night or over a weekend is inconsequential, so the maintenance team can wait to deal with it during work hours.

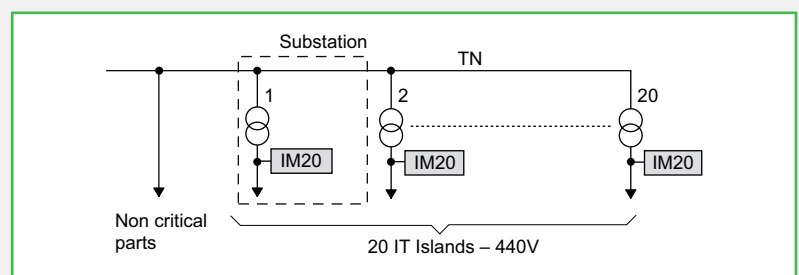

Vigilohm IM20 are monitoring each IT network. Their alarm relay is used to inform the maintenance team of a fault through a light indicator.

Since the processes are not critical here, no insulation fault locator is used and fault location is done by sequential opening of the circuit breakers. IM20 is used for its good compatibility with variable speed drives.



Benefits

- Initial investment is limited to the transformers and the Insulation Monitors
- Return on investment done within a few years through maintenance optimization and power supply continuity of the process
- Choice of an IT earthing system provides other benefits preventive maintenance by monitoring changes in insulation values; increased equipment life since IT earthing system limits the stress endured by equipment during a fault

Application Water and Waste Water

Context

Ungrounded networks can be found in water production and distribution sites, as well as in wastewater treatment plants. Continuity of service is a requirement for the critical parts of the installation such as pumps, and water treatment processes.

What is at stake

Limiting the number of occurrences of unplanned downtimes is key. Unexpected interruptions may result in the discharge of untreated water into public waterways, creating a public health hazard and resulting in fines for the plant, or in odor nuisance for the neighborhood.

What are the constraints from the installation

- Numerous variable speed drives and pollution with harmonics
- Important number of feeders, and requirement to perform fault location without powering down the network
- Emergency gensets should be monitored when they are off-line, to prevent any risk of failure when they must be started.
- Harsh environment (salty environment, outdoor conditions)

Vigilohm solution

Vigilohm range provides solutions from basic to advanced insulation monitoring. Insulation Fault Locators will allow to save on OPEX. Communication features of IM20, IM400, IFL12C and IFL12MC can be leveraged for easier maintenance.

Case study: Waste water treatment plant

Ungrounded networks are used for critical processes, such as the pumps which can never be stopped. The network includes several 250kW drives. The insulation monitoring solution is based on IM400 and IFL12: an alarm is sent in case of insulation fault, faulty feeder is indicated by IFL12, keeping the continuity of service.

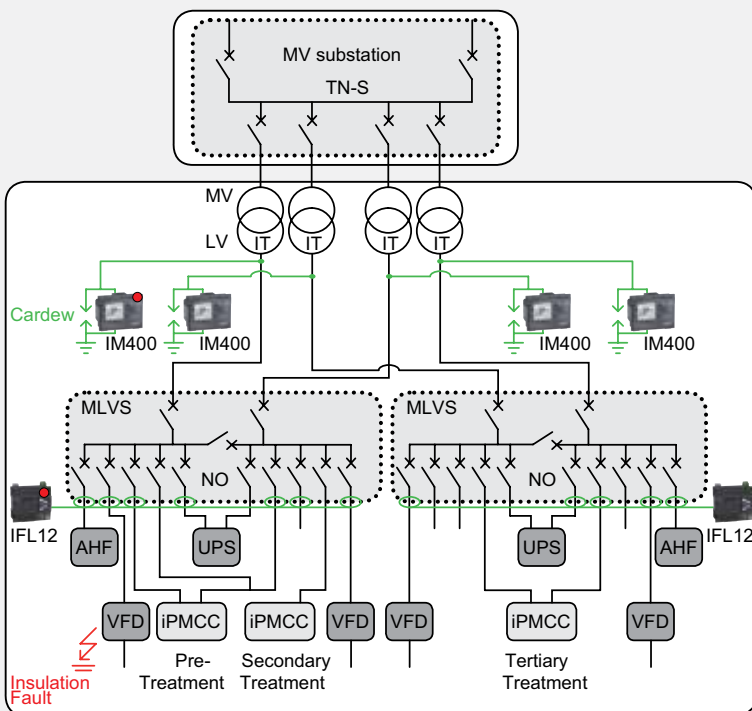

Benefits

- Processes carry on running, even in case of an insulation fault.
- Locators reduce maintenance time by identifying the faulty feeder.
- Compliance of the solution with variable speed drives.

Application

Infrastructure and Transportation



Context

Transportation infrastructures include rail, subway, bus charging stations, airports, tunnels... All these applications have in common a need for electrical network availability, as well as the safety constraints specific to sites receiving public.

Examples of networks that can be ungrounded on the installation include:

- In Rail: signaling, escalators, lighting, smoke extractors. IT ungrounded earthing systems are commonly used for the signaling network in subway.
- In Airports : lighting, control tower, take-off path
- In Tunnels: lighting, smoke extractors.

What is at stake

Continuity of service is key, since an unexpected downtime of the network means the interruption of customer service, an important financial loss and user dissatisfaction.

Insulation faults can also cause safety issues if they lead to a malfunction of lighting system, train or plane signaling, or smoke extraction systems.

What are the constraints from the installation

- Electrical networks may be quite long (such as signaling networks in rail) and disturbed
- Installations can be in AC or DC (for example, car charging stations, power supply for trolley bus)
- Electrical equipment may have to be installed in harsh or outdoor environment – having to withstand variations of temperature and humidity
- Environment may be dusty such as in subway or tunnels

Vigilohm solution

- IM400 with IFL locators: use of insulation fault locators is typically interesting on large networks
- Insulation monitoring alarms can be retrieved in the supervision system of the site (IM400 with IFL12C or IFL12MC)
- Leakage capacitance is monitored
- Conformally coated products for harsh environment (IM400C, IFL12MCT)
- IM9-OL for off-line insulation monitoring.

Case study: Airport

Several parts of the airport are using ungrounded networks:

- Taxi way lighting
- Control Command room of the radar
- Airport apron, where aircraft are parked, unloaded, loaded, refueled.

IM400, IFL12MC are used to monitor the system and communicate with the

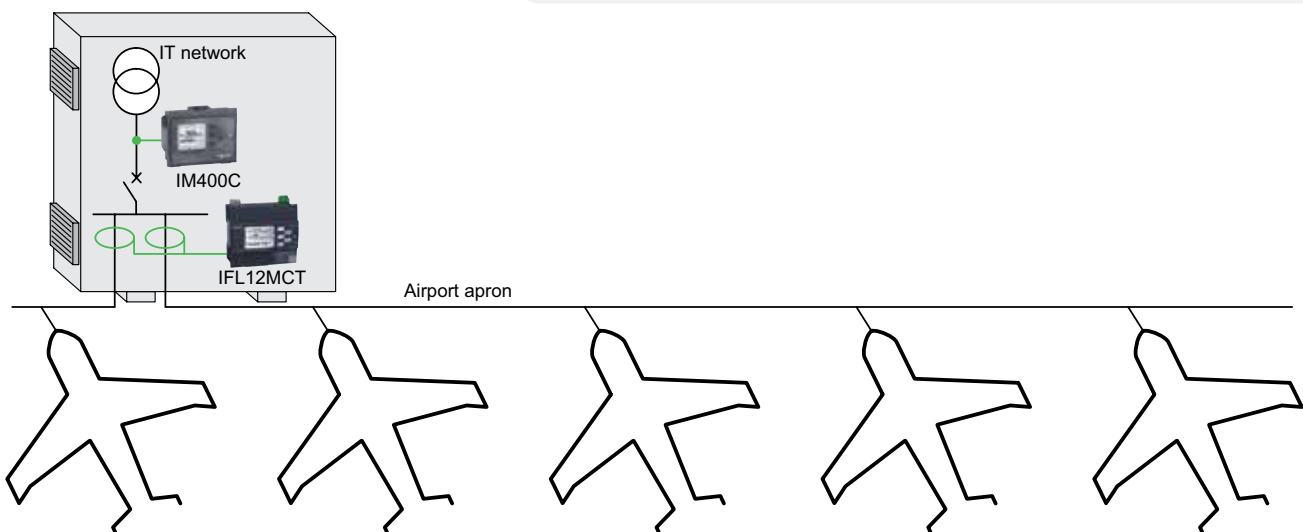

Application Utilities

Context

Ungrounded networks can be found in several power generation applications:

- In nuclear power plants: control command, inverters, backup power supply. Both MV and LV part can be ungrounded
- In hydro electric utilities: control command, DC motors.

What is at stake

Continuity of service is essential for safety reasons. An insulation fault shall not interrupt the installation. For this reason, ungrounded networks are used.

What are the constraints from the installation

Devices may need to be qualified by the utility, going through a series of performance tests, EMC compatibility, temperature and humidity validation, seismic tests etc.

Devices are often required to have a failsafe mode, or a functional safety certification.

Vigilohm solution

Vigilohm devices have been used in this segment for decades, their reliability and robustness has been tested.

- Seismic tests have been passed
- IM400 is SIL2 certified
- IM400 and IFL12MC meet the requirement of having several settable alarm thresholds
- IM400THR is used for MV insulation monitoring

Case study: 48VDC Control command network in power plant

Global insulation monitoring and insulation measurements per feeder are required on this ungrounded network, as well as 3 levels of alarm thresholds.

The solution is based on IM400+IFL12MC:

- two alarm thresholds are set at the IM400 level (alarm and prealarm)
- one alarm threshold can be set for each feeder from the IFL12MC.

The "Control Command" injection mode of IM400 allows to limit the level of injected signal; and limits the disturbance of sensitive equipment on the network.



To know more:

SIL Safety Integrity Level certification

This certificate evaluates the level of operation safety of a device. SIL includes 4 levels: SIL1, SIL2, SIL3 and SIL4 (listed in order of increased safety level).

Certification is delivered by an external laboratory, which tests the hardware and software reliability, even in case of an internal failure of the device.

Application Photovoltaic



Context

Photovoltaic installations such as solar farms with central inverters are installations with specific constraints.

Whether the solar panels are using monocrystal and polycrystal technology, or thin film technology, the recommendation is to have the panels ungrounded during the night, to ensure of proper detection of insulation faults.

What is at stake

The main risk on these installations is the risk of fire, some previous cases having shown that they may happen due to insulation faults improperly monitored.

Maintaining a permanent productivity of the solar farm is essential, so any insulation monitoring solution in place should be optimized and cause minimal disruption, while assuring safety on the site.

What are the constraints from the installation

Solar farms are very large surfaces covered with photovoltaic modules, producing high voltage DC energy.

Short circuit currents produced by photovoltaic modules are too low to trigger usual protections, as compared to nominal current.

Photovoltaic generators cannot be shut off as long as the photovoltaic modules are exposed to the sun. In addition, photovoltaic farms are often monitored remotely.

As for the devices to be installed on site, they should be compatible with challenging mission profiles, including high temperatures when the production is on during the day, and low temperatures when the production is off at night.

Which standards apply?

- IEC standard 60364 Part 712: Solar photovoltaic power supply systems
- IEC standard 62109-1 and -2: Safety of Power Converters for use in PV power systems
- IEC TS 62548: Photovoltaic arrays – Design Requirements.

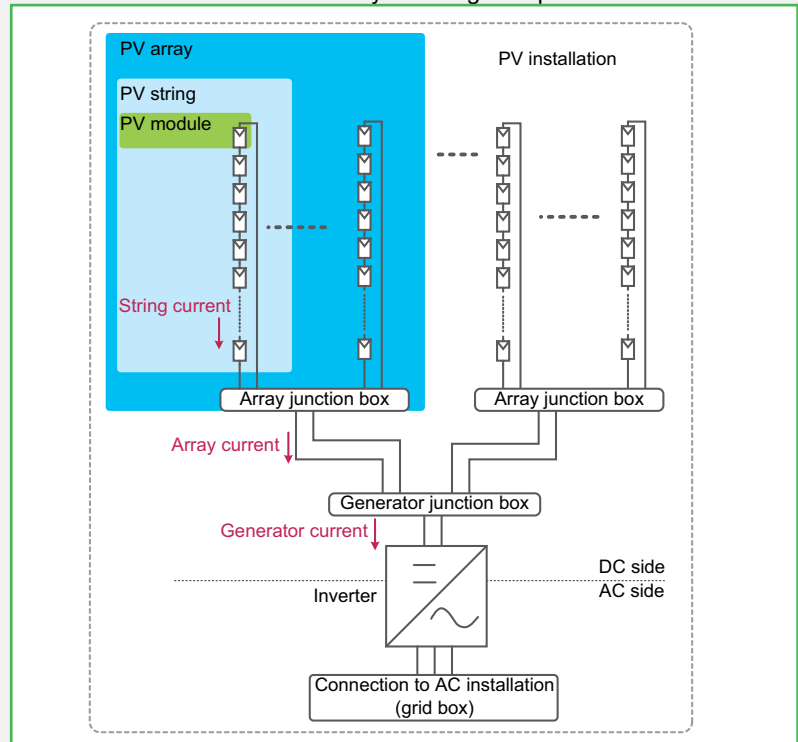

Application Photovoltaic

Vigilohm solution

IM400C and its voltage adaptors (IM400-1700C or IM400VA2) is the solution:

- Very low frequency injected signal (0,0625Hz) to reduce the influence of the network leakage capacitance
- Reliable and accurate measurement of the insulation
- Alarm threshold can be set as low as to 0,04kOhms, reducing occurrences of alarms due to daily variation of insulation
- Compatible with both DC and AC installations: if the inverter is not galvanically isolated, the insulation of AC part is also monitored
- Conformally coated products, proven compatibility with harsh environment
- Native Modbus RS485 for connection to a supervision.

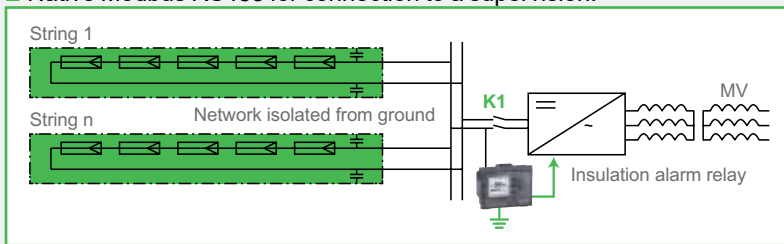

Case study: Monitoring of a solar farm and recording of historical insulation

An unexpected interruption can cost approximately 8% of the photovoltaic yield per hour. There are penalties to pay if the target is not achieved, since the photovoltaic operating contracts specify a level of availability of the installation.

Using ungrounded network with proper insulation monitoring helps improve the solar farm availability and revenues.

To improve insulation monitoring, and understand the typical patterns of insulation level over day and night; a continuous measurement and logging of network insulation and leakage capacitance to ground was implemented by connecting the Vigilohm IM400C to an Energy Server Com'X510.

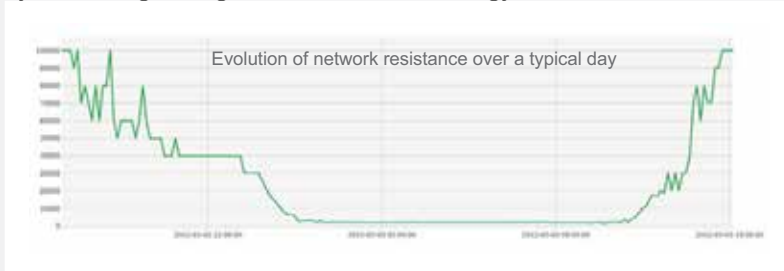

To know more
Vigilohm brochure:
**Keep the power running
safely in the sun**



**Specifying Insulation
Monitoring Devices
for Utility-Scale Solar
Safety**



Application Marine



Context

IT networks are commonly used in marine installations to ensure of continuity of service, limit risk of fire and explosion and ensure of people and equipment safety.

All types of ships are concerned: cargo, carrier or container ships, tankers, military vessels, FPSO or cruise ships, military ships...

Vessels are frequently in IT from the generators to the final loads.

What is at stake

When at sea, due to the environmental conditions and the distance to external assistance, a ship's crew has no other choice but to work independently. In all situations – including both normal operations and also exceptional events – the crew must face and fix problems alone.

Potential risks include electrical shock, cable overheating or fire, explosion, loss of control of the navigation equipment. To mitigate these risks, ungrounded networks are used.

What are the constraints from the installation

Marine conditions are harsh. Insulation faults are frequent on ships due to severe weather, lightning, humidity, vibration and stress on equipment, intense and concentrated heat in confined space.

The electrical networks on ships can be disturbed networks including equipment such as variable speed drives (for example in the machinery, propulsion and thrusters networks).

Standards in Marine

Ships' design require the approval from Classification Societies. The IACS (International Association of Classification societies) include among others Bureau Veritas, Lloyd's Register of British and Foreign Shipping, Germanischer Lloyd, DNV, ABS, RS...

Vigilohm products comply with Classification societies requirements.

Classification Societies

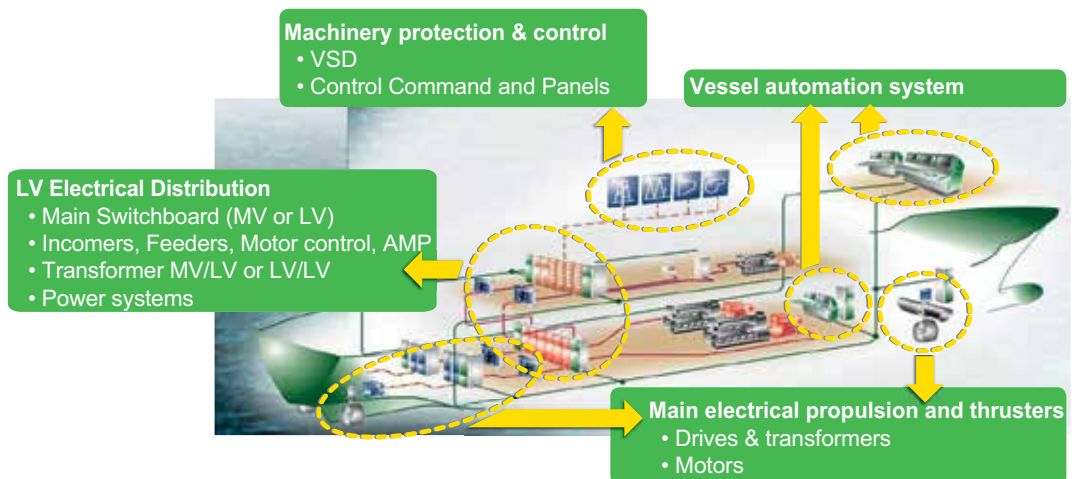

Application Marine

Vigilohm solution

Vigilohm provides a complete range of products compatible with marine applications.

- Simple IMD such as IM10, IM20 can meet the needs for small networks with only a few feeders, where no automatic fault locators are needed
- Larger networks, with numerous feeders, can be monitored with IM400 together with automatic fault locators of IFL12 range.
- Some vessels include a medical zone and operating theaters, that can be monitored by IM10-H, IM15H, IM20-H and fault locator IFL12H
- If products need to be placed in harsh environment, the conformally coated products IM400C and IFL12MCT can be selected
- The insulation monitoring of off-line devices (lift, pump, motors) can be done with IM9-OL
- The communicating products of Vigilohm range (IM20, IM400, IFL12C, IFL12MC) will allow sending insulation alarms into the supervision system of the ship through Modbus RS485 communication.
- Vigilohm products comply with DNV, Bureau Veritas, RMRS, ABS classification societies requirements (refer to product datasheets for details)
- IM400 complies with UL508, UL FS (Functional Safety) for a higher level of safety.

Case Study: Cruise Ship

The solution is made of IM400 and IFL12MC for an advanced insulation monitoring of the system. A PME system is used to retrieve insulation measurements and alarms through Modbus communication. IM9-OL are used for monitoring of off-line generators.

To know more
Vigilohm brochure:
**Keep the power running
safely at sea**

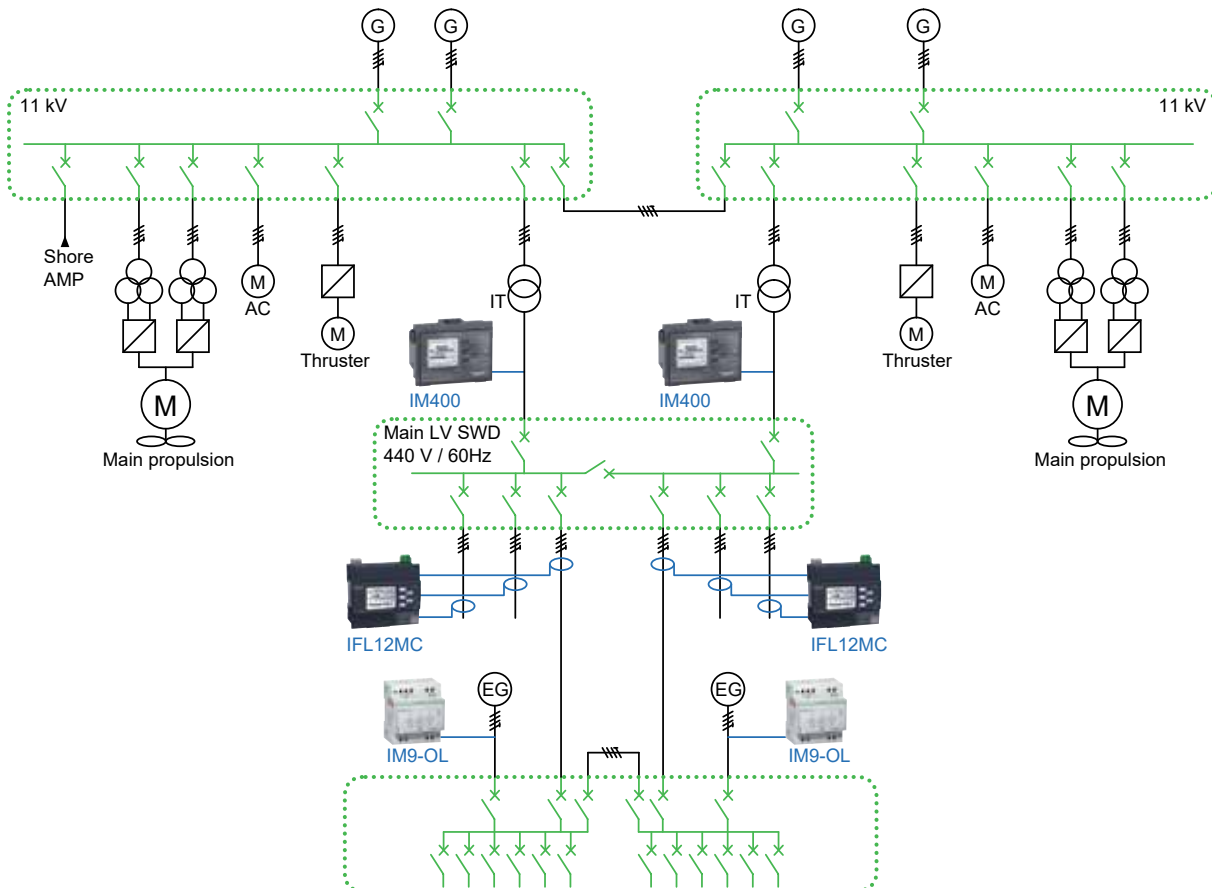

Application

Insulation Monitoring of Off-Line Equipment



Safety equipment in buildings opened to the public



Smoke extractor in a tunnel

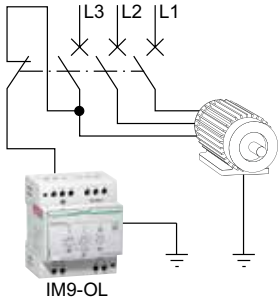

IM9-OL is compatible with any grounding system: IT, TN, TT.

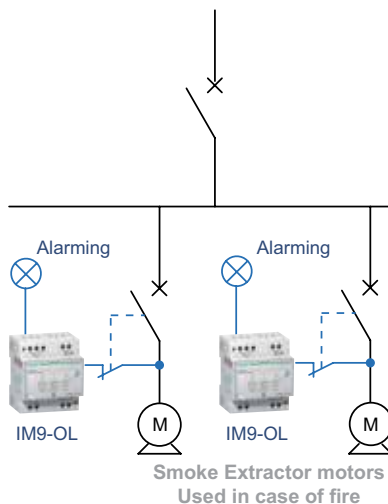

Context

Failure to start some motors or generators can have serious consequences.

Equipment failing to start can be due to insulation problems, appearing when the equipment is de-energized.

This concerns equipment on any type of earthing system (not only IT, but also TT, TN).

What is at stake

Environmental conditions, such as humidity, dust, and rust can have serious effects on a piece of equipment when it not used for a long period. Humidity may accumulate in microscopic cracks in the insulation.

This can result in a downgrade in the insulation level of the equipment.

Eventually, when the equipment must be used and is energized again, the risk is that it will fail to start, due to an insulation problem.

This can have serious consequences, in terms of safety for people or in terms of financial losses. In the event of a dead short, powering up a motor can even result in a high fault current that can destroy the motor (if it is configured with TN grounding).

Vigilohm Solution

IM9-OL is designed to monitor insulation of off-line equipment:

- Compatible with any earthing system
- Compatible with AC and DC networks, and with MV equipment using an appropriate timer relay
- Pre-alarm threshold from 0.5 MΩ to 10 MΩ
- Motor-no-start threshold from 0.25 MΩ to 2 MΩ.

Local regulations for buildings open to the public

In some countries (for example in France according to NFC 15-100), the insulation monitoring of safety equipment in buildings opened to the public is mandatory when they are not in use. Insulation faults must be signaled to ensure equipment will be operational when needed. Safety equipment include smoke extractors, fire pumps.

Customer case study: Smoke extractor in a station

Monitoring of their insulation with IM9-OL while they are not used allows to anticipate the detection and correction of faults; thus ensuring that the smoke extractors will be operating if they are needed in case of fire.

The alarm relay of IM9-OL is used to report remotely the alarm.

This simple solution allows to ensure of passengers' safety in the station.

Application

Harsh Environment

Context

Indoor installation of products is not always possible in installations such as industrial sites, railways and other infrastructure sites, marine or photovoltaic sites.

In such configuration, electrical devices are submitted to harsh environmental constraints, including high variations of temperature or humidity.

Harsh environments may also include salty or dusty atmosphere.

What is at stake

It is required to ensure that the Insulation Monitoring Devices will be able to perform well over time, with no premature ageing, despite of the environmental constraints applied.

What are the constraints on the installation

As an example, a product installed in the electrical shelter on a photovoltaic site has to withstand:

- Temperatures going down to -40°C during the night, and up to $+70^{\circ}\text{C}$ during the day
- Fast ramp up of temperature in the morning
- High relative humidity

These important variations can lead to condensation on the electronic cards of the devices.

Vigilohm Solution

A range of conformally coated products is available, providing an extended range of temperature and humidity level supported. This makes them suitable for use in outdoor environments (under shelter).

- Insulation Monitor: IM400C
- Voltage Adaptors: IM400-1700C and IM400VA2



Benefits of Conformally Coated Products

	IM400	IM400C	IFL12MC	IFL12MCT IFL12LMCT
Conformally Coated	No	Yes	No	Yes
Temperature strength				
For operation	-25°C to $+55^{\circ}\text{C}$	-25°C to $+70^{\circ}\text{C}$	-25°C to $+55^{\circ}\text{C}$	-25°C to $+70^{\circ}\text{C}$
For storage	-40°C to $+70^{\circ}\text{C}$	-40°C to $+85^{\circ}\text{C}$	-40°C to $+70^{\circ}\text{C}$	-40°C to $+85^{\circ}\text{C}$
Relative humidity	$\leq 92\%$	$\leq 95\%$	$\leq 92\%$	$\leq 95\%$
Installation				
Indoor	Yes	Yes	Yes	Yes
Outdoor, under shelter	No	Yes	No	Yes

Application

Medium Voltage Ungrounded Networks



Context

Ungrounded networks can be found in Medium Voltage networks (between 1,5kV and 33kV) for improved continuity of service. Examples of applications include:

- Mining, Minerals and Metals
- Marine and Shore connection, with 6,6kV supply of large ships when at sea port
- Oil and Gas sites, with explosive atmosphere
- Power generation, such as nuclear and gas power plants
- Airports taxi lighting system.

What is at stake

For such installations, continuity of service of the MV network is essential. Safety risks may also be involved for some sites which are in environment with a risk of explosion: the faulty current in case of insulation fault shall be limited.

What are the constraints on the installation

Insulation Monitors need to withstand the voltage level of these networks. They should provide a settable kOhm alarm threshold. It is also required to limit the ferro resonance phenomenon on the MV network.

Vigilohm Solution

Schneider Electric released the first MV insulation monitor 50 years ago. We offer a full solution for insulation monitoring of MV ungrounded networks, from 1,5kV to 33kV, which includes:

- MV voltage transformers
- Insulation Monitor: Vigilohm IM400THR and IM400LTHR
- Ground Adaptor: P1N

We also have expertise in order to limit the ferro resonance phenomenon.

Customer Case Study : Chemical Manufacture

This site includes ten sources of 5,5kV. Processes for the manufacture of chemical components take up to one day and cannot be interrupted, as the risk is to waste all raw material involved. Ungrounded networks are in placed on the MV network, monitored by IM400THR. Insulation faults, for example due to dust on aerial glass isolators, are detected by the IM400THR, while maintaining continuity of service.

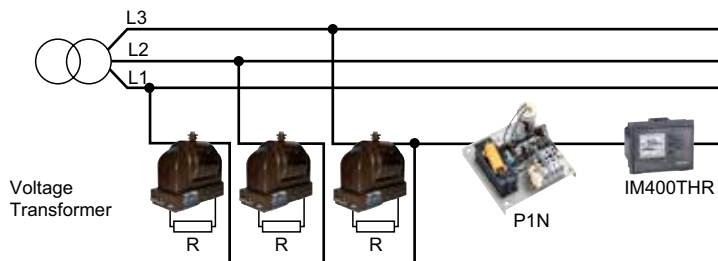

Application DC Networks

Context

Direct Current has been used for a long time, and in many fields. It offers major advantages, in particular simple storage with batteries. Ungrounded earthing is selected when continuity of service is critical on the application. Indeed, with ungrounded networks, the occurrence of an insulation fault does not require the trip of protections. DC ungrounded applications include high availability applications such as :

- Nuclear power generating stations
- Other power generating stations
- Oil and Gas power distribution stations
- Other DC control systems
- Telecom
- Control command systems.

Photovoltaic fields are a specific case of ungrounded DC applications.

What is at stake

It is required to ensure of continuity of service.

What are the constraints on the installation

In order to be compatible with the monitoring of ungrounded DC installations, the Insulation Monitor must not operate by the injection of a DC component on the network. Instead, the IMD should inject an alternative signal on the network.

Vigilohm Solution

- IM9 is not suited for DC network monitoring. Instead the IM10, IM20 and IM400 will be selected: they inject low frequency component (1,25Hz or 2,5Hz).
- Insulation Fault Locators (IFL12 range) are also compatible with the monitoring of DC networks.
- Vigilohm range also includes products with 24-48VDC power supply for ease of installation if the device shall be powered by the network it monitors: IM400L, IM400LTHR, IFL12L, IFL12LMC



Case studies:

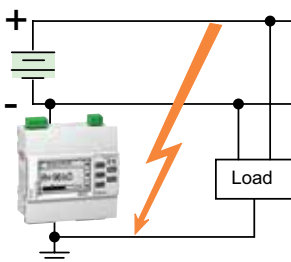

Insulation Monitor injection is wired to one polarity. Whenever the network includes charges or batteries, the injection signal flows over both polarities, allowing to detect an insulation fault affecting any part of the network.

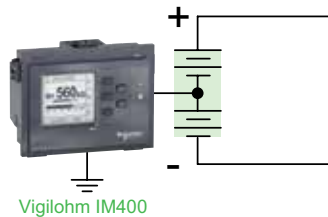

Example of installation with IM400 injection connected at the central point of battery.

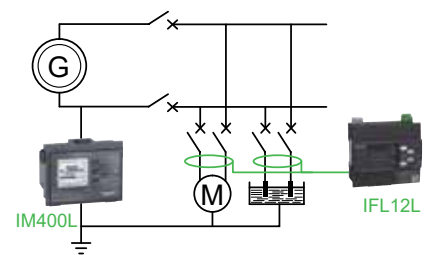









IM400L and IFL12L are powered by the network they monitor; removing the need of external power supply.

To know more
Refer to the document "Circuit breakers for direct current applications up to 380 V DC: Choosing and implementing protective devices"



Selection Guide

IM Selection Guide	Off-Line Motor	Small AC System	Small & Medium AC / DC System		Large AC/DC System	MV system	Hospital	
	IM9-OL	IM9	IM10	IM20	IM400	IM400THR	IM10-H IM15H	IM20-H
								
Application								
Healthcare							○	○
Harsh environment and Photovoltaic					IM400C			
Standard Applications		○	○	○	○			
Off-Line Motor (TT, TN, IT)	○							
Medium Voltage								
IT Power System Type								
No disturbance system		○	○	○	○	○		
Low level of disturbance			○	○	○	○		
High level of disturbance					○	○		
Power Supply								
24-48V DC					IM400L	IM400LTHR	110-230V AC 125-250V DC	
110-440V AC/DC	○	○	○	○	○	○		
Fault Location								
Manual fault locator		With XGR	With XGR	With XGR	○			
Automatic fault locator					IFL12, IFL12C		IFL12H	
Per feeder: adjustable threshold, measurement, custom name					IFL12MC			
Information and Communication								
Preventive Insulation Alarm	○				○	○		
Output relay								
Insulation Alarm Output Relay	○	○	○	○	○	○	○	○
Modbus RS485				○	○	○		○
Historical data				○	○	○		○

Selection Guide

IFL Selection Guide								
	IFL12	IFL12L	IFL12C	IFL12MC	IFL12LMC	IFL12LMCT	IFL12MCT	IFL12H
Application								
Healthcare								●
Harsh environment						●	●	
Standard Applications	●	●	●	●	●			
IT Power System Type								
No disturbance system	●	●	●	●	●	●	●	
Low level of disturbance	●	●	●	●	●	●	●	
High level of disturbance				●	●	●	●	
Power Supply								
24-48V DC		●			●	●		110-230V AC 125-250V DC
110-440V AC/DC	●		●	●			●	
Information and Communication								
Insulation Alarm	●	●	●	●	●	●	●	●
Output Relay	●	●	●	●	●	●	●	●
Modbus RS485			●	●	●	●	●	●
Historical data				●	●	●	●	●

Choosing the Optimal Solution

According to the type of network

- An off-line load: IM9-OL
- A small purely AC network (with no DC component): IM9
- An IT island, AC and/or DC: IM10 or IM20
- A critical room in a healthcare facility: IM10-H, IM15H, IM20-H and IFL12H
- A larger network, or a network requiring automatic fault location: IM400 with IFL12 range
- Networks requiring deeper analysis per feeder: IM400 and IFL12MC.

According to the network constraints

- For large networks, it is recommended to monitor their leakage capacitance (IM20, IM400)
- On highly disturbed networks, with many variable speed drives, it is recommended to select an IM400 for optimal performance
- Depending on the nominal voltage of the network, a voltage adaptor may be required together with the Insulation Monitor, or an IM400THR.

Range Overview - Industrial Networks

A simple range to meet your needs

Industrial Networks

Monitoring and Control

Power Monitoring & SCADA system



Communication and Simple Monitoring

Gateway, Data logger & Web Server



Insulation Monitoring Devices

Monitoring of the global network insulation



Insulation Fault Locators

Identification of the faulty feeder



Toroids

Used along with the Fault Locators



(*) Alarm relay position can be sent to a supervisor via a Smartlink.

Range Overview - Healthcare

Dedicated offers for critical rooms compliant with IEC60364-7-710

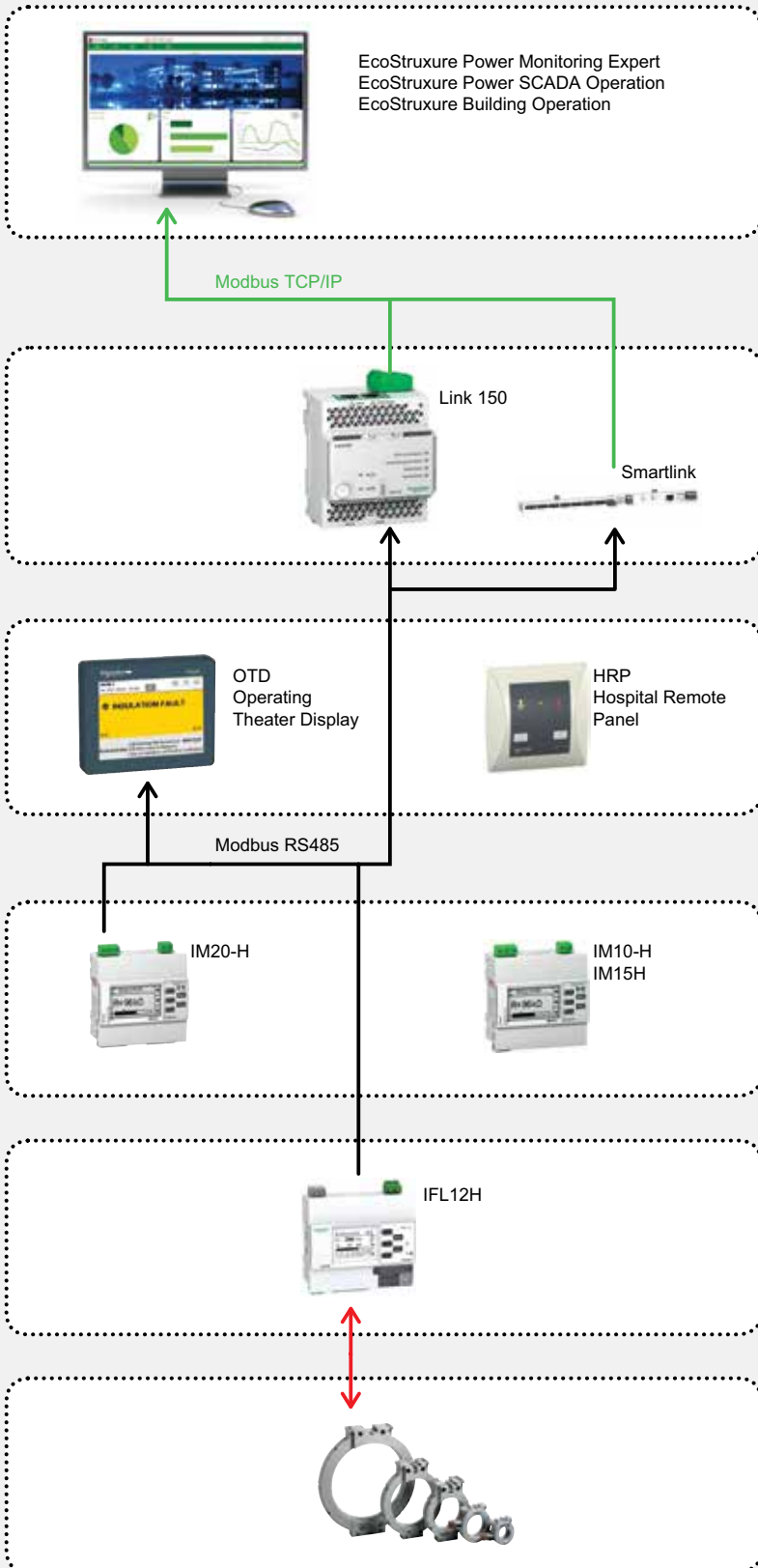

Monitoring and Control

Power Monitoring & SCADA system

Communication

Gateway

Local Displays

HMI in the medical room

Insulation Monitoring Devices

Monitoring of the global network insulation

Insulation Fault Locators

Identification of the faulty

Toroids

Used along with the Fault Locators

Motor off-line Insulation Monitor



IM9-OL



Commercial reference

- IMD-IM9-OL.

Functions

IM9-OL monitors the insulation resistance of Off-Line equipment (motors) by injecting a DC signal between this equipment and the ground.

- Measures the insulation resistance.
- Detects an insulation fault according to the set alarm thresholds.
- Opens the contacts of the Prev-Alarm relay in case the threshold is breached.
- Closes the contacts of the «Motor no start» relay in case the alarm threshold is breached. Can also be used to prevent the equipment from starting

Main features

- Injection of a DC measuring signal
- Power supply: 110...415 VAC, or 125...250 VDC.
- 1 settable alarm (motor no start) and 1 settable pre-alarm thresholds.
- 2 NO-NC relays.
- Local self test.
- 1 rotary switch to allow or not motor to start.

Application

- Compatible with any grounding arrangement, such as TT or TN or IT.
- Off-Line equipment such as fire pumps, motors or generators.

Standards & certifications

- IEC61557-8 Ed.2014
- IEC61010-1 Ed.2010
- UL 61010-1 Ed3.2012
- IEC61326-4 Ed.2012



Dimensions (mm)

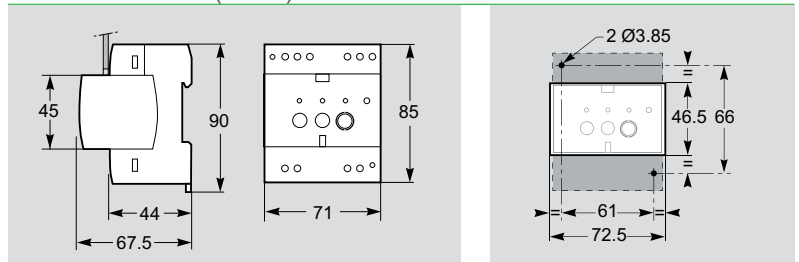

Examples of architectures

Direct on line Starting Motor

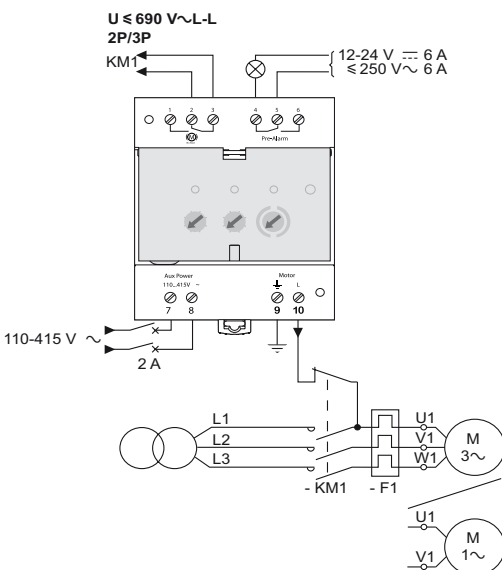

Star-Delta Starting Motor

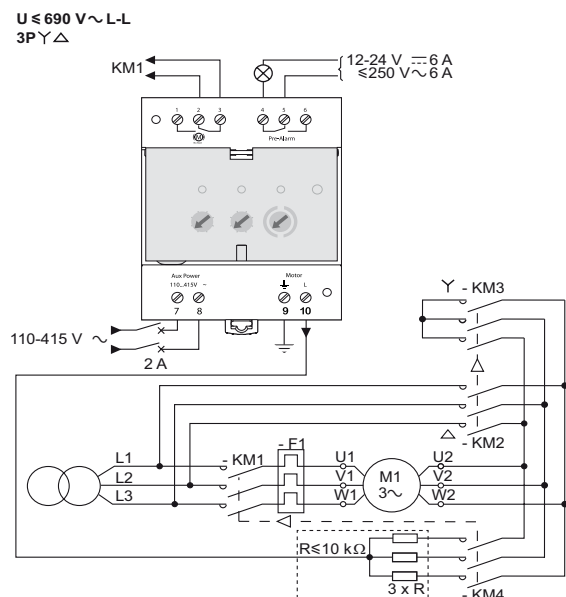

Motor off-line Insulation Monitor

Physical Description

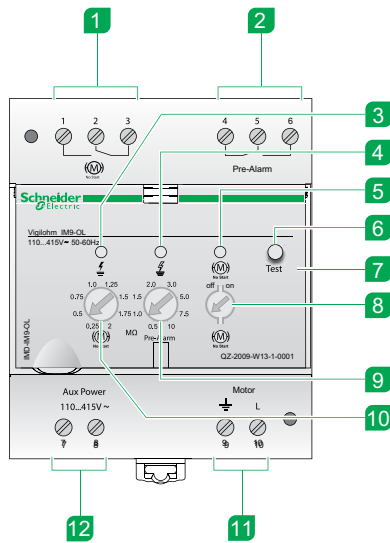

- 1 Motor no start relay (control of KM1)
- 2 Failsafe pre-alarm relay
- 3 Motor insulation fault LED
- 4 Pre-alarm LED
- 5 Motor no start LED
- 6 Test button
- 7 Transparent sealable cover
- 8 Motor no start selector
ON: «Motor no start» activated
OFF: «Motor no start» inhibited
- 9 Pre-alarm threshold setting
- 10 Motor no start threshold setting
- 11 Injection
- 12 Auxiliary power supply

General characteristics

Commercial name		IM9-OL
Type of network to monitor		
Max phase to phase voltage		≤ 690 VAC
Frequency		Any frequency
Grounding arrangement		IT/ TT / TN
Power Supply		
Auxiliary power supply	Voltage	110...415 VAC / 125...250 VDC
	Tolerance (%)	+/-15%
	Frequency	45-400 Hz
	Maximum consumption	7VA
Product Performances		
Range for insulation resistance	Accuracy at 10 kΩ, 1 μF	< 15%
Fault signaling thresholds	Preventive alarm	0.5; 1; 1.5; 2; 3; 5; 7.5; 10 MΩ
	Alarm	0.25; 0.5; 0.75; 1; 1.25; 1.5; 1.75; 2 MΩ
Response time		≤ 2 s
Self test	Manual	Local
Output relay	Quantity	2
	Type of contact	Changeover
	Breaking capacity AC	250V / 6A
	Breaking capacity DC	12...24V / 6A
	Setting	Prev-Alarm: Failsafe Motor no start: Standard
Measurement voltage (max)		20V
Measurement current (max)		20 μA
Measuring frequency		DC
Internal resistance		500 kΩ
Environment		
Protection degree	Front	IP40
	Rear	IP20
Overvoltage category		OVC3
Temperature strength	For operation	-25°C to +55°C
	For storage	-40°C to +70°C
Relative humidity		≤ 92%



IM9



Functions

IM9 monitors the insulation resistance of an IT network by injecting a DC signal between this network and the ground

- Measures the insulation resistance of the network
- Detects an insulation fault according to the set alarm threshold
- Closes or opens a contact relay in case of alarm.

Main features

- Injection of a DC measuring signal
- Power supply: 110...415 VAC, or 125...250 VDC
- 1 settable alarm and 1 settable pre-alarm thresholds
- 1 NO-NC alarm relay
- Local and remote self test

Commercial reference

- IMD-IM9.

Application

- Pure AC networks with no DC component.
- Network of limited dimension (<5km of cable) with no disturbance loads.

Compatible auxiliaries

- Earthing Impedance: Zx
- Surge Limiter: Cardew C
- Mobile insulation fault locator: XGR + XRM + probes.

Standards & certifications

- IEC61557-8 Ed.2014
- IEC61010-1 Ed.2010
- UL 61010-1 Ed3.2012
- IEC61326-4 Ed.2012



Connection

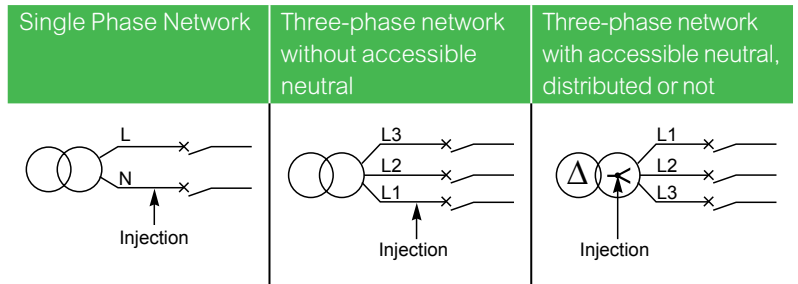

Examples of architectures

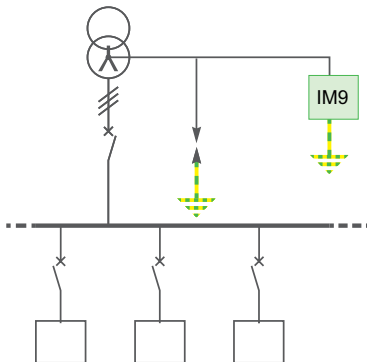

Dimensions

Dimensions (mm)

Flush mounting (mm)

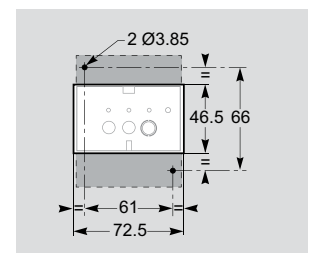
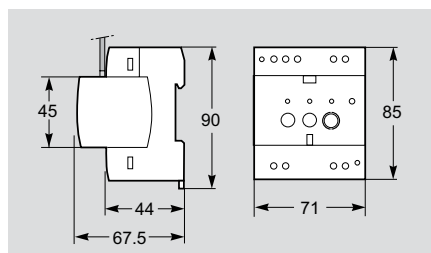

Physical Description

Failsafe wiring

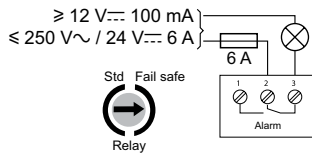

Standard wiring

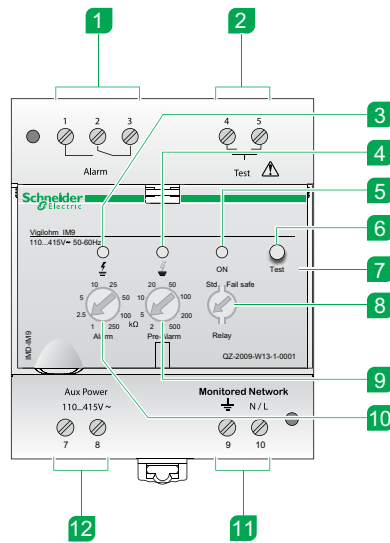
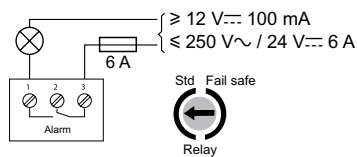

- 1 Alarm relay
- 2 Remote test
- 3 Alarm LED
- 4 Pre-alarm LED
- 5 Operating indicator light
- 6 Test button
- 7 Transparent sealable cover
- 8 Failsafe or standard alarm relay setting
- 9 Pre-alarm setting
- 10 Alarm setting
- 11 Injection
- 12 Auxiliary power supply

General characteristics

Commercial name		IM9
Type of network to monitor		
AC (max phase to phase voltage)	Connected to neutral	600 VAC
	Connected to phase	480 VAC
DC (max line voltage)		Not compatible
Frequency		Purely AC networks
Grounding arrangement		IT / ungrounded
Power Supply		
Auxiliary Power Supply	Voltage	118-415 VAC / 125-250 VDC
	Tolerance	+/-15%
	Frequency	45-440 Hz
	Maximum consumption	7VA
	Recommended protection	1A
Product Performances		
Insulation resistance	Accuracy at 10 k Ω , 1 μ F	<15%
Fault signaling thresholds	Preventive alarm	2; 5; 10; 20; 50; 100; 200; 500 k Ω
	Alarm	1; 2,5; 5; 10; 25; 50; 100; 250 k Ω
Response time		$\leq 2 \text{ s}$
Self test	Manual	Local and remote
Output relay	Quantity	1
	Type of contact	Changeover
	Breaking capacity AC	250V / 6A
	Breaking capacity DC	12-24V / 6A
	Setting	Failsafe or standard
Measurement voltage (peak)		16V
Measurement current (peak)		70 μ A
Measuring frequency		DC
Internal resistance		230 k Ω
Environment		
Protection degree	Front	IP40
	Rear	IP20
Overvoltage category		OVC3
Pollution degree		2
Temperature strength	For operation	-25°C to +55°C
	For storage	-40°C to +70°C
Relative humidity		$\leq 92\%$



IM10



IM20



Commercial reference

- IMD-IM10.
- IMD-IM20.

Functions

IM10 and IM20 monitor the insulation resistance of an IT network by injecting an AC signal between this network and the ground.

- Measure and display of the network insulation resistance
- Measure and display of the network leakage capacitance and impedance (IM20)
- Detection of insulation fault according to the set alarm thresholds
- Signal of insulation fault through the display and the output relay
- Signal of insulation fault through communication port (IM20)

Main features

- AC measuring signal, for AC, DC and AC/DC systems.
- Power supply: 110...230 VAC, or 125...250 VDC.
- Measures the insulation resistance from 0.1kΩ to 10MΩ.
- Measures earth leakage capacitance from 0.1 to 70 μF (IM20)
- 1 settable alarm (and 1 settable pre-alarm threshold on IM20).
- Automatic and manual Self test.

Application

- Industrial AC, DC and AC/DC networks.
- Typical segments: Industry, Power generation, Marine, Railways, Airport, Oil&Gas, Mining, Water, Heating & Cooling, lift, etc.

Compatible auxiliaries

- Voltage adaptors: IM20-1700 with IM20.
- Earthing Impedance: ZX.
- Surge Limiter: Cardew C.
- Mobile insulation fault locator: XGR + XRM + probes.
- Gateways and supervision with IM20 only. Example: Com'X510, Link150, Smartlink, PME, PSO.

Standards & certifications

- IEC61557-8 Ed.2014
- IEC61010-1 Ed.2010
- UL 61010-1 Ed3.2012
- IEC61326-4 Ed.2012



Examples of architectures

Local alarm

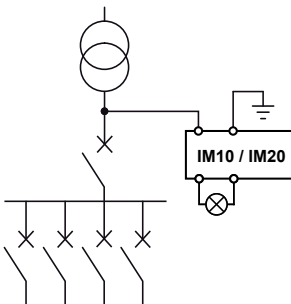

Local + Remote alarm via relay output

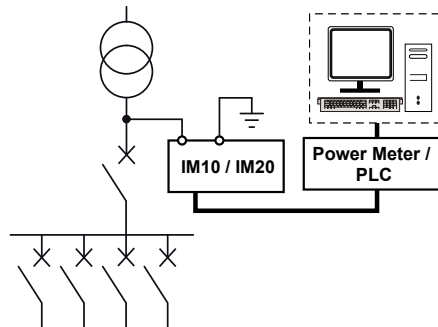

Local + Remote alarm via communication port

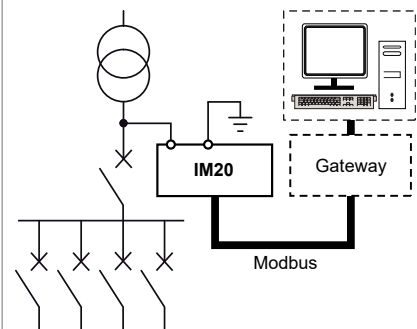

Physical Description

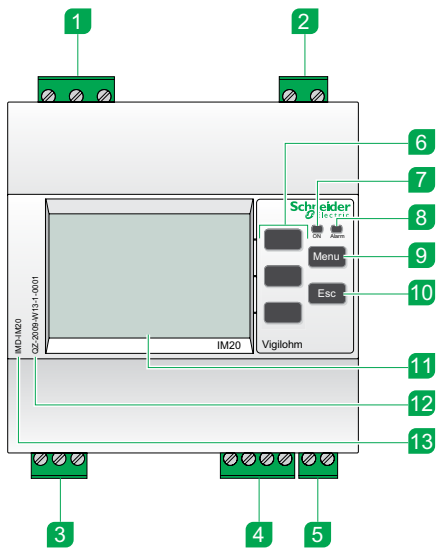

- 1 Injection terminal block
- 2 Auxiliary power supply terminal block
- 3 Alarm relay terminal block
- 4 Modbus port terminal block (IM20)
- 5 Injection inhibition input (IM20)
- 6 Contextual menu buttons
- 7 Operating indicator light
- 8 Insulation alarm indicator light
- 9 Menu button
- 10 ESC button to return to the previous menu or cancel a parameter entry
- 11 Display
- 12 Serial number
- 13 Product reference (IMD-IM10 or IMD-IM20)

Dimensions

Dimensions (mm)

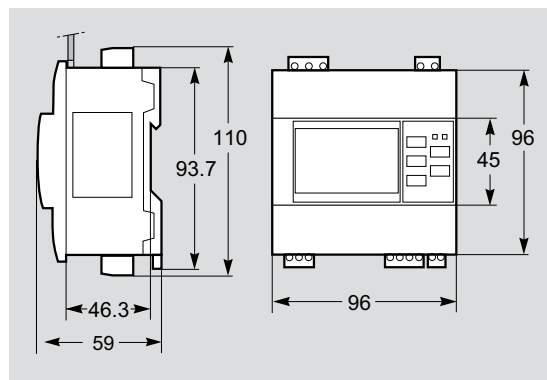

Flush mounting (mm)

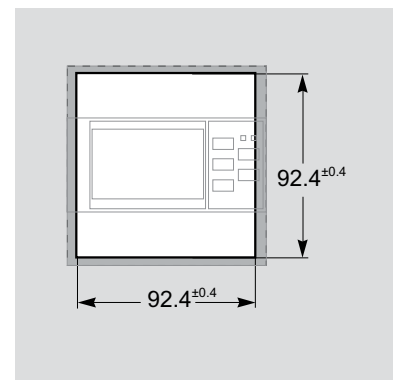

Connection

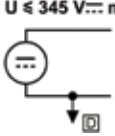
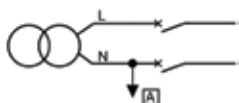
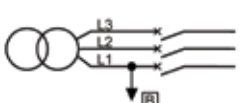
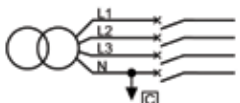
	Direct current	Single Phase Network	Three-phase network without accessible neutral	Three-phase network with accessible neutral, distributed or not
	DC $U \leq 345 \text{ V} \text{--- max.}$ 	P+N $U \leq 480 \text{ V} \sim \text{max.}$ 	3P $U \leq 480 \text{ V} \sim \text{L-L max.}$ 	3P+N $U \leq 600 \text{ V} \sim \text{L-L max.}$ 
AC Connection to Line			$U_{LL} \leq 480 \text{ V AC}$	
AC Connection to Neutral		$U_{LN} \leq 480 \text{ V AC}$		$U_{LL} \leq 600 \text{ V AC}$
DC Connection to Line	$U < 345 \text{ V DC}$			

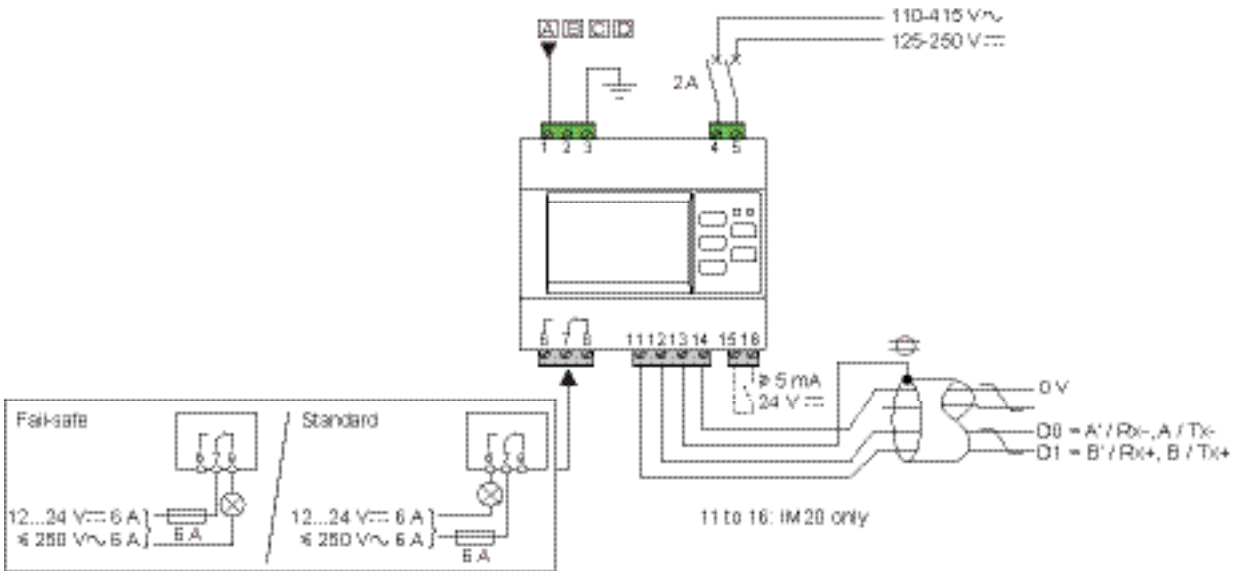

General characteristics

Commercial name		IM10	IM20
Type of network to monitor			
Max phase to phase voltage	Connected to neutral	600 VAC	
	Connected to phase	480 VAC	
Max line voltage		345 VDC	
Network max capacitance		40µF	70µF
Frequency		AC and DC networks	
Grounding arrangement		IT / ungrounded	
Power Supply			
Auxiliary power supply	Voltage	110...415 VAC / 125...250 VDC	
	Tolerance (%)	+/-15%	
	Frequency	45...440 Hz or DC	
	Maximum consumption	12VA	
	Recommended protection	2A	
Product Performances			
Range for insulation resistance	Reading	0.1KΩ to 10MΩ	
	Accuracy at 10 kΩ, 1 µF	< 5%	
Earth leakage capacitance	Reading	No	0.1µF to 70µF
	Accuracy at 10 kΩ, 1 µF	No	5%
Fault signaling thresholds	Preventive alarm	1KΩ to 1MΩ	
	Alarm	0,5KΩ to 500KΩ	
Settable alarm delays		0s to 7200s	
Response time		≤ 5 seconds	
Intermittent fault capture		No	Yes
Injection inhibition		No	Yes, settable as NO or NC contact
Self test	Automatic	Every 5 hours	
	Manual	Yes via HMI	
Output relay	Quantity	1	
	Type of contact	Changeover	
	Breaking capacity AC	250V / 6A	
	Breaking capacity DC	12...24V / 6A	
	Setting	Fail-safe or standard	
Communication port		No	Modbus RS485
Measurement voltage (peak)		53V	
Measurement current (peak)		< 0.5mA	
Measuring frequency		1,25Hz	
Internal resistance		110KΩ	
Environment			
Protection degree	Front	IP52	
	Rear	IP20	
Overvoltage category		OVC3	
Pollution degree		2	
Temperature strength	For operation	-25°C to +55°C	
	For storage	-40°C to +70°C	
Altitude max.		Up to 3000 m	
Relative humidity		≤ 92%	
Human Machine Interface			
Multilingual interface	8 languages	En, Fr, Es, Po, Zh, It, De, Ru	
Others	Historical resistance log	None	Yes
	Time stamped Event log	None	Yes

Vigilohm IM10-H, IM15H, IM20-H Insulation monitoring devices for medical premises



IM10-H



IM20-H



Functions

IM10-H, IM15H, IM20-H monitor the insulation resistance of an IT network by injecting a signal between this network and the ground.

- IM10-H measures and displays the insulation resistance of the network and detects an insulation fault according to the set alarm thresholds. IM10-H triggers an alarm on insulation resistance via the output relay and the display.
- IM15H, in addition to IM10-H features, monitors the IT transformer overload and overheat. It generates an alarm via output relay and display in case of overload or overheat.
- IM20-H in addition to IM15H features, is equipped with Modbus RS485 communication port.
- IM10-H, IM15H, IM20-H allow fault location with IFL12H or XD312-H.

Commercial reference

- IMD-IM10-H.
- IMDIM15H.
- IMD-IM20-H.

Standards & certifications

- IEC61557-8 Ed.2014
- IEC61010-1 Ed.2010
- UL 61010-1 Ed3.2012
- IEC61326-4 Ed.2012
- IEC60364-7-710



Main features

- AC measuring signal, designed for medical premises AC, DC and AC/DC systems
- Power supply: 110-230 VAC, or 125-250 VDC.
- Measures the insulation resistance from 0.1 KΩ to 10 MΩ.
- 1 settable alarm > 50 KΩ.
- Automatic and manual Self test.

Application

- IT Medical network only as per IEC60364-7-710.

Compatible auxiliaries

- Insulation Fault locator: IFL12H and XD312-H
- Gateways and supervisions - Examples: Link150, Smartlink, PME, PSO, EBO (IM20-H)
- Remote displays- Example: HRP (IM10-H, IM15H, IM20-H), OTD (IM20-H).

Examples of architectures

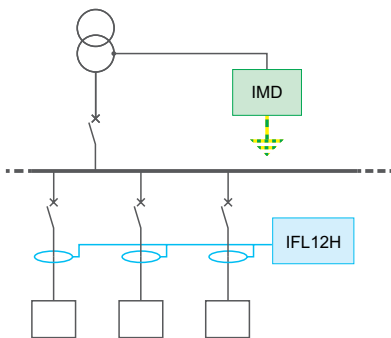

Dimensions

Dimensions (mm)

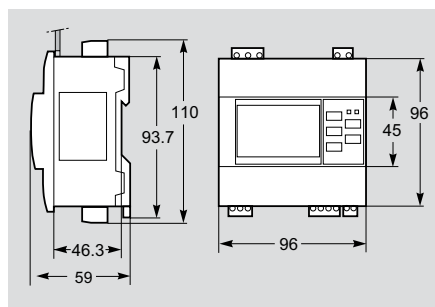

Flush mounting (mm)

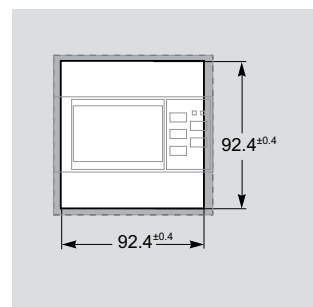

Vigilohm IM10-H, IM15H, IM20-H

Insulation monitoring devices for medical premises

Physical Description

IM10-H

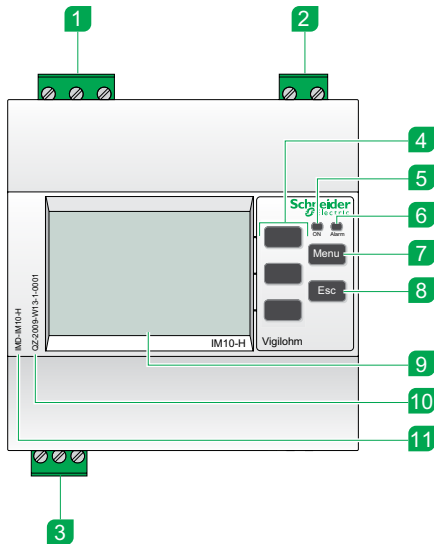

- 1 Injection terminal block
- 2 Auxiliary power supply terminal block
- 3 Insulation alarm relay terminal block
- 4 Contextual menu buttons
- 5 Operating indicator light
- 6 Insulation alarm indicator light
- 7 Menu button
- 8 ESC button to return to the previous menu or cancel a parameter entry
- 9 Display
- 10 Serial number
- 11 Product reference

IM15H and IM20-H

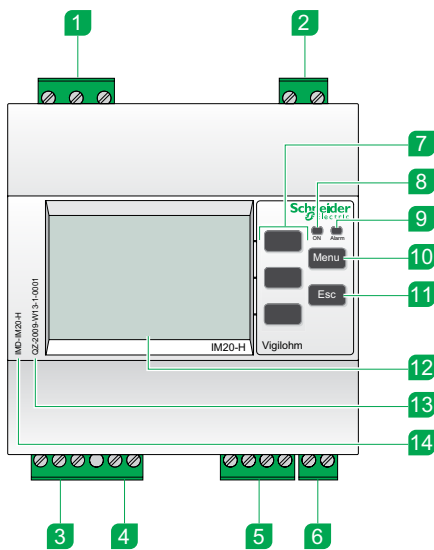

- 1 Injection terminal block
- 2 Auxiliary power supply terminal block
- 3 Insulation alarm relay and overheat/overload alarm relay
- 4 1 A or 5 A CT input for transformer's secondary current monitoring
- 5 Modbus communication terminal block (IM20-H)
- 6 Bimetal input for transformer's temperature monitoring
- 7 Contextual menu buttons
- 8 Operating indicator light
- 9 Insulation alarm indicator light
- 10 Menu button
- 11 ESC button to return to the previous menu or cancel a parameter entry
- 12 Display
- 13 Serial number
- 14 Product reference

Vigilohm IM10-H, IM15H, IM20-H

Insulation monitoring devices for medical premises

Connection

IM10-H

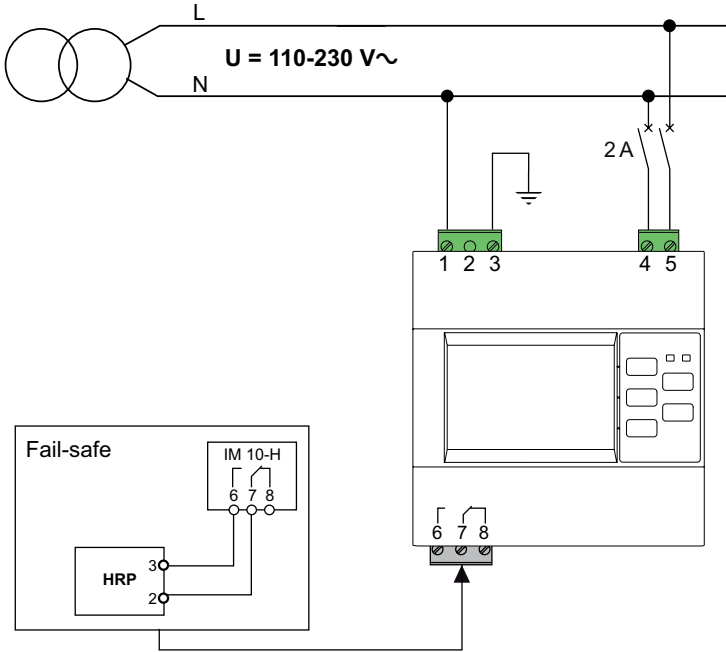

IM15H and IM20-H

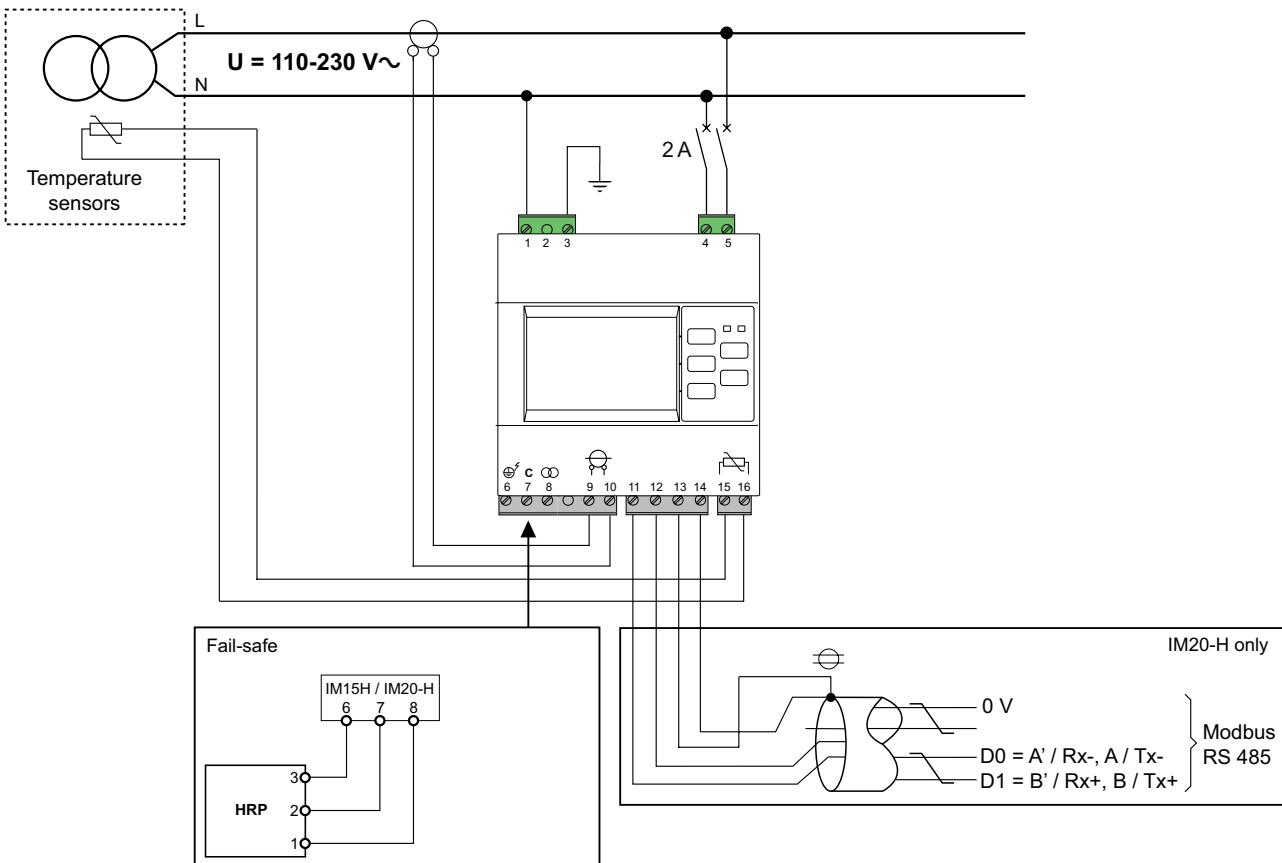

Insulation monitoring devices for medical premises

General characteristics

Commercial name		IM10-H	IM15H	IM20-H
Type of network to monitor				
AC (max phase to phase voltage)	Connected to neutral		≤ 230 VAC +15 %	
DC (max line voltage)			≤ 230 VDC +15 %	
Frequency			50/60Hz	
Grounding arrangement			Medical IT / ungrounded	
Power Supply				
Auxiliary Power Supply	Voltage	110...230 VAC / 125...250 VDC		
	Tolerance (%)	+/-15%		
	Frequency	45-440 Hz		
	Maximum consumption	12VA		
	Recommended protection	2A		
Product Performances				
Range for insulation resistance	Reading	0,1kΩ to 10 MΩ		
	Accuracy at 10 kΩ, 1 μF	< 5%		
Settable alarm threshold		50KΩ to 500KΩ		
Response time		≤ 4s		
Self test	Automatic	Every 5 hours		
	Manual	Yes via menu		
Inputs	Transformer overheat	No	Yes	
	Transformer overload	No	Yes	
Output relay	Quantity	1	2	
	Type of contact	Changeover	Static	
	Breaking capacity AC	250V / 6A	-	
	Breaking capacity DC	12...24V / 6A	12-48VDC ≤ 50mA	
Communication port		No	Modbus RS485	
Measurement voltage (peak)		25V		
Measurement current (peak)		0.2 mA		
Measuring frequency		2,5Hz		
Internal resistance		141 kΩ		
Environment				
Protection degree	Front	IP52		
	Rear	IP20		
Overvoltage category		OVC3		
Pollution degree		2		
Temperature strength	For operation	-25°C to +55°C		
	For storage	-40°C to +70°C		
Altitude max.		Up to 3000 m		
Relative humidity		≤ 92%		
Human Machine Interface				
Multilingual interface	8 languages	En, Fr, Es, Po, Zh, It, De, Ru		
Others	Historical resistance log	No	Yes	
	Time stamped Event log	No	Yes	



IM400



IM400C



Commercial reference

- IMD-IM400 (standard).
- IMDIM400L (24-48VDC power supply)
- IMD-IM400C (Conformally coated).

Functions

Monitors the insulation resistance of IT/ungrounded or High Resistance Grounded (HRG) networks by injecting a low frequency signal between network and earth.

- Measures and displays the insulation resistance, capacitance and impedance of the network.
- Detects an insulation fault according to the set alarm thresholds.
- Triggers a pre-alarm and alarm via the 2 relays, the modbus port and the display.
- Compatible with the range of Insulation Fault Locators.

Main features

- Adaptive multifrequency measuring signal, for AC, DC and AC/DC networks.
- Power supply: 100-440 VACDC, and 24-48VDC (IM400L).
- Measures the insulation resistance from 10 Ω to 10 MΩ.
- Measures earth leakage capacitance from 0.1 to 500µF or 5500µF (IM400C).
- 1 settable alarm and 1 settable pre-alarm thresholds.
- Large screen, event log and historical data.
- Native Modbus RS485 communication port.
- Conformally coated (IM400C).

Application

- Control Command networks, including sensitive loads such as PLCs, I/Os, sensors.
- Power Circuits networks, including power loads and power electronics such as speed drives, inverters, rectifiers, etc...
- Photovoltaic utility scale sites, e.g. 4 MW per inverter (IM400C).
- Typical segments: Industry, Power generation, Marine, Railways, Airport, Oil&Gas, Mining, Water, Heating & Cooling, lifts, ...requesting continuity of service even in case of earth insulation fault.
- Harsh environment with IM400C.

Standards & certifications

- IEC61557-8 Ed.2014
- IEC61010-1 Ed.2010
- UL 61010-1 Ed3.2012
- IEC61326-4 Ed.2012
- UL1998 (IM400C)
- UL Functional Safety (IM400C)
- SIL2 (IM400C)
- ATEX (IM400C)



Compatible auxiliaries

- Voltage adaptors: PHT1000; IM400-1700 & IM400-1700C; IM400VA2 (IM400C),
- Earthing Impedance: ZX.
- Surge Limiter: Cardew C.
- Insulation Fault locator: IFL12 series (except IFL12H), and former ranges XD301, XD312 and XD308C.
- Mobile insulation fault locator: XRM + probes.
- Gateways and supervisions - Examples: Com'X 510, Link150, Smartlink, PME, PSO.

Examples of architectures

Control Command mode

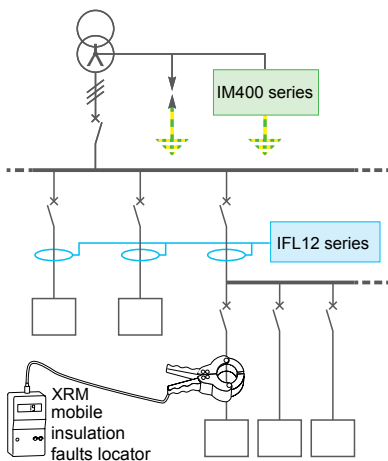

Power Circuit mode

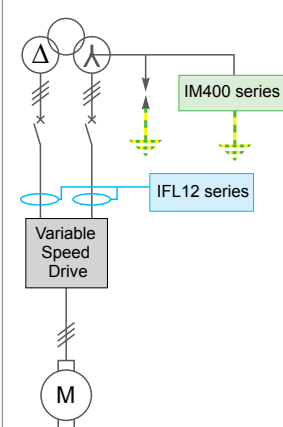

Photovoltaic mode

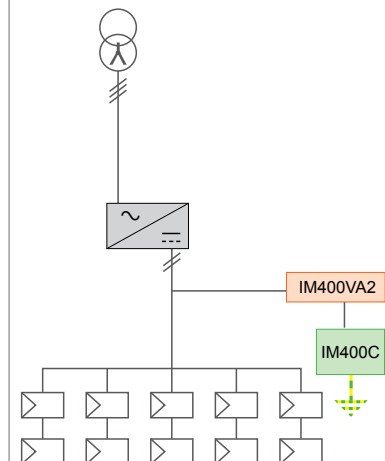

Physical Description

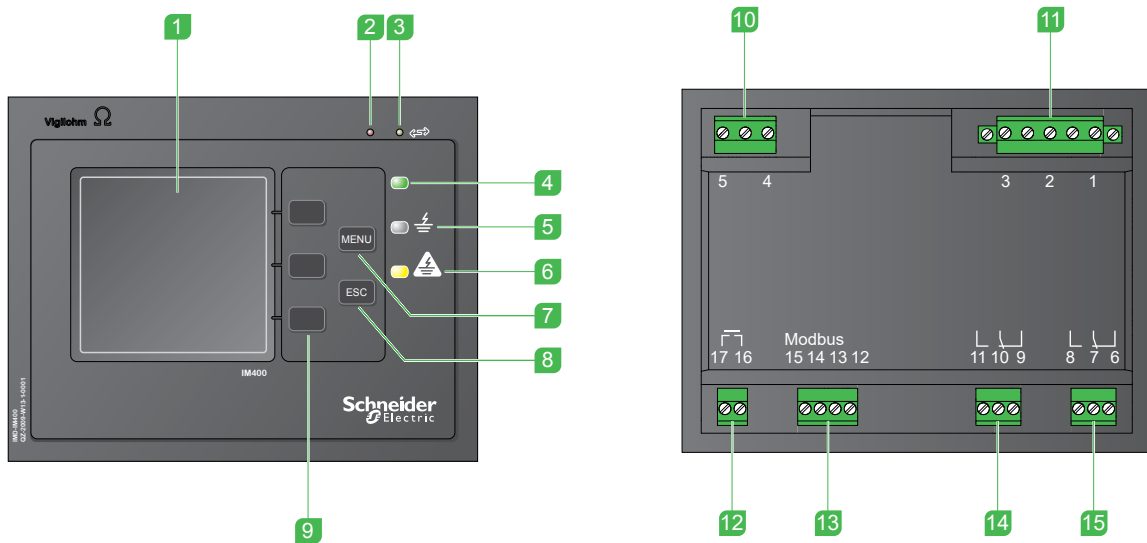

- 1 Display
- 2 Red indicator light for product status
- 3 Yellow indicator light for Modbus communication indication
- 4 Green indicator light for correct insulation indication
- 5 White indicator light for preventive insulation alarm
- 6 Yellow indicator light for insulation alarm
- 7 MENU button
- 8 ESC button for returning to previous menu or canceling a parameter entry

- 9 Contextual menu buttons
- 10 Auxiliary power supply terminal
- 11 Injection terminal
- 12 Injection inhibition input terminal
- 13 Modbus RS-485 terminal
- 14 Preventive insulation alarm relay terminal
- 15 Insulation alarm relay terminal

Dimensions

Dimensions (mm)

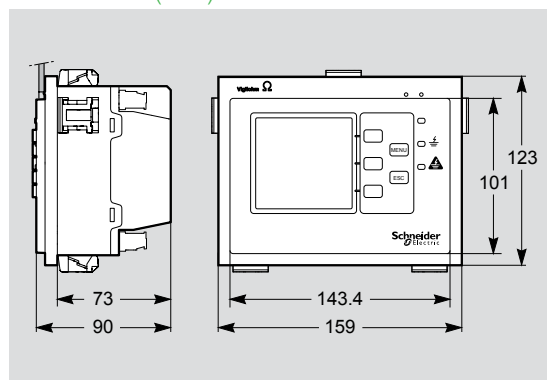

Flush mounting (mm)

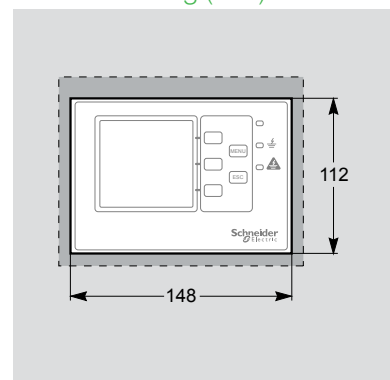

Connection

	Direct current	Single Phase Network	Three-phase network without accessible neutral	Three-phase network with accessible neutral, distributed or not
AC Connection to Line			$U_{LL} \leq 480 \text{ VAC}$	
AC Connection to Neutral		$U_{LN} \leq 480 \text{ VDC}$		$U_{LL} \leq 830 \text{ VAC}$
DC Connection to Line	$U \leq 480 \text{ VDC}$			
Fault Location	Yes	Yes	Yes	Yes

Compatibility between Insulation Monitors and Voltage Adaptors		
IM400-1700 / IM400-1700C	PHT1000	IM400VA2
IM400 / IM400L / IM400C	IM400 / IM400L / IM400C	IM400C
$U_{LL} < 1700 \text{ VAC}$ neutral injection	$U_{LL} < 1700 \text{ VAC}$ neutral injection	$U_{LL} < 1700 \text{ VAC}$ neutral injection
$U_{LL} < 1000 \text{ VCA}$ injection on one phase	$U_{LL} < 1000 \text{ VCA}$ injection on one phase	$U_{LL} < 1500 \text{ VCA}$ injection on two phases
$U < 1000 \text{ VDC}$, injection at (+) or (-)	$U < 1200 \text{ VDC}$, injection at (+) or (-)	$U < 1500 \text{ VDC}$, injection at (+) and (-)
Not compatible with fault location	Compatible with fault location	Not compatible with fault location

Refer to the Voltage Adaptor pages for features and location capabilities

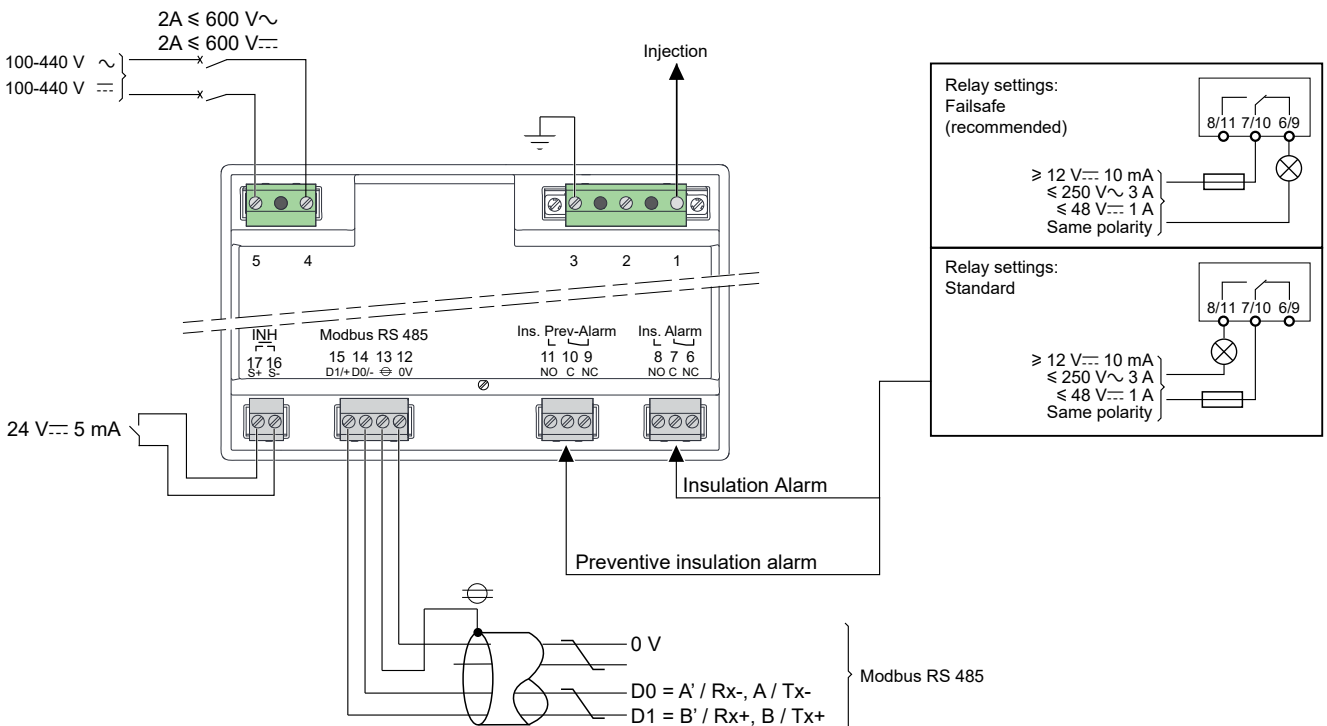

Insulation Monitor

General characteristics

Commercial name		IM400	IM400L	IM400C
Type of network to monitor				
AC (max phase to phase voltage)	Connected to neutral	≤ 830VAC		
	Connected to phase	≤ 480VAC		
DC (max line voltage)		≤ 480VDC		
Network max capacitance		500 μF		5500 μF
Frequency		AC and DC networks		
Grounding arrangement		IT / High resistance grounded		
Power Supply				
Auxiliary supply voltage	Voltage	100-440 VACDC	24-48 VDC	100-440 VACDC
	Tolerance	+/-15%		
	Frequency	50 / 60 / 400 Hz	-	50 / 60 / 400 Hz
	Maximum consumption	25 VA / 10 W		
	Recommended protection	2A		
Product Performances				
Range for insulation resistance	Reading	10 Ω to 10 MΩ		
	Accuracy at 10 kΩ, 1 μF	< 5%		
Earth leakage capacitance	Reading	0.1 μF to 500 μF	0.1 μF to 500 μF 0.1 μF to 5500 μF for Photovoltaic application	
	Accuracy at 10 kΩ, 1 μF	5%		
Fault signaling thresholds	Preventive alarm	1 kΩ to 1 MΩ		
	Alarm	0.04 kΩ to 500 kΩ		
Settable alarm delays	Preventive alarm	0s to 7200s		
	Alarm	0s to 7200s		
Response time		4 or 40s (depending on filtering)	4 or 40 or 400s (depending on filtering)	
Intermittent fault capture		Yes		
Self test	Automatic	Every 5 hours		
	Manual	Yes		
Input	Injection inhibition	Yes, settable as NC or NO contact		
Output relay	Quantity	2		
	Type of contact	Changeover		
	Breaking capacity AC	250V / 3A		
	Breaking capacity DC	48V / 1A, 3mA min.		
	Setting	Failsafe or standard or mirror		
Communication port		Modbus RS485		
Operating Modes		Control-Command or Power Circuit	Control-Command or Power Circuit or Photovoltaic	
Measurement voltage (peak)		15V, 33V, 120V		
Measurement current (peak)		375 μA, 825 μA, 3mA		
Measuring frequency		1.25 and 2.5Hz	1.25 and 2.5Hz or 0.0625Hz	
Internal resistance		40 kΩ		
Environment				
Protection degree	Front	IP54		
	Rear	IP20		
Overvoltage category		300 V/OVC3 / 600 V/OVC2		
Pollution degree		2		
Temperature strength	For operation	-25°C to +55°C	-25°C to +70°C	
	For storage	-40°C to +70°C	-40°C to +85°C	
Altitude max.		Up to 3000m		
Relative humidity		≤ 92%	≤ 95%	
Conformally coated		No	Yes	
Human Machine Interface				
Multilingual interface	8 languages	En, Fr, Es, Po, Zh, It, De, Ru		
Others	Historical resistance log	Yes		
	Time stamped Event log	Yes		



IM400THR



Commercial reference

- IMDIM400THR.
- IMDIM400LTHR.

Standards & certifications

- IEC61557-8 Ed.2014
- IEC61010-1 Ed.2010
- UL 61010-1 Ed3.2012
- IEC61326-4 Ed.2012
- NFC13200, Medium Voltage

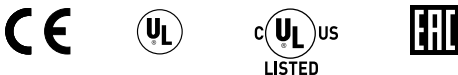

Functions

Monitors the insulation resistance of IT medium voltage networks (AC) by injecting a DC signal between network and earth.

- Detects an insulation fault according to the set alarm thresholds.
- Triggers a pre-alarm and alarm via the 2 relays, the modbus port and the display.
- Measures and displays the insulation resistance of the network.

Main features

- Compatible with alternative MV networks in association with the properly rated Voltage transformer.
- Power supply:
 - IM400THR: 100-440 VAC / 100-440 VDC
 - IM400LTHR: 24-48 VDC
- Measures the insulation resistance from 10 Ω to 10 MΩ.
- 1 settable alarm and 1 settable pre-alarm thresholds.
- Large screen, event log and historical data.
- Native RS485 communication port.

Application

- Suited for IT Medium Voltage distribution networks and loads
- Typical segments: Electrical Distribution, Industry, Power generation, Marine, Airport, Oil&Gas, Mining, lifts, etc requesting continuity of service even in case of earth insulation fault.

Compatible auxiliaries

- Voltage adaptors: P1N and voltage transformer.
- Gateways and supervisions - Examples: Com'X 510, Link150, Smartlink, PME, PSO.

Examples of architectures

Three-phase network with accessible neutral

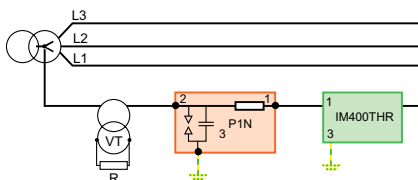

Three-phase network without accessible neutral

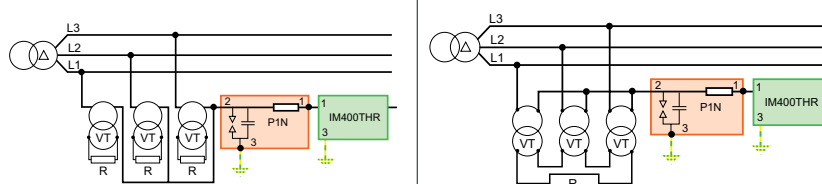

Physical Description

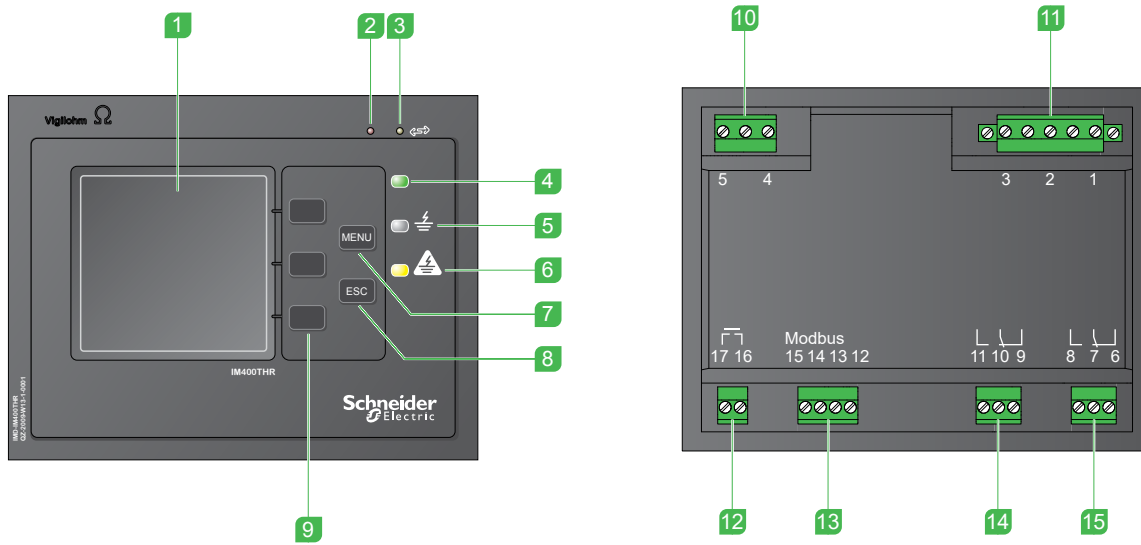

- 1 Display
- 2 Red indicator light for product status
- 3 Yellow indicator light for Modbus communication indication
- 4 Green indicator light for correct insulation indication
- 5 White indicator light for preventive insulation alarm.
- 6 Yellow indicator light for insulation alarm
- 7 MENU button
- 8 ESC button for returning to previous menu or canceling a parameter entry

- 9 Contextual menu buttons
- 10 Auxiliary power supply terminal
- 11 Injection terminal
- 12 Injection inhibition input terminal
- 13 Modbus RS-485 terminal
- 14 Preventive insulation alarm relay terminal
- 15 Insulation alarm relay terminal

Dimensions

Dimensions (mm)

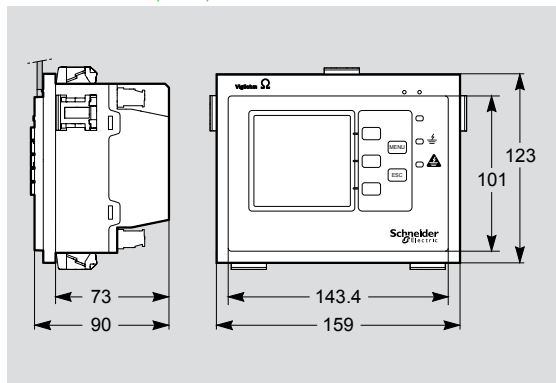

Flush mounting (mm)

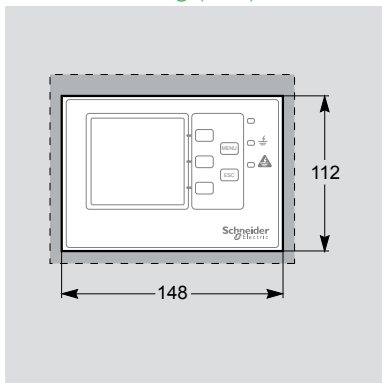

Connection

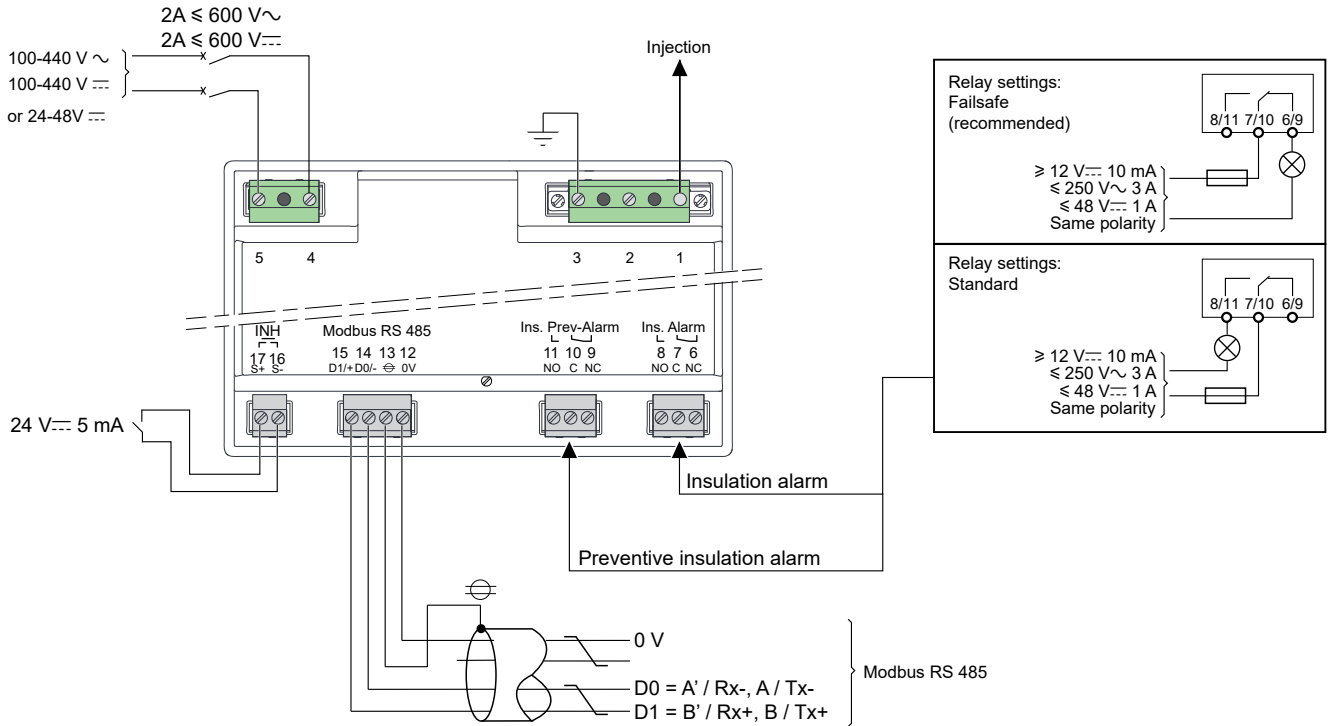

General characteristics

Commercial name		IM400THR	IM400LTHR
Type of network to monitor			
AC (max phase to phase voltage)	Connected to neutral	< assigned voltage of the Voltage transformer	
	Connected to phase	< assigned voltage of the Voltage transformer	
DC (max line voltage)		Not compatible	
Frequency		Purely AC networks	
Grounding arrangement		IT / ungrounded medium voltage	
Power Supply			
Auxiliary supply voltage	AC	100-440 VAC	-
	DC	100-440 VDC	24-48 VDC
	Tolerance	+/-15%	
	Maximum consumption	25 VA / 10 W	
	Recommended protection	2A	
Product Performances			
Range for insulation resistance	Reading	10 Ω to 10 MΩ	
	Accuracy at 10 kΩ, 1 μF	5%	
Fault signaling thresholds	Preventive alarm	1 kΩ to 1 MΩ	
	Alarm	0.1 kΩ to 500 kΩ	
Settable alarm delays	Preventive alarm	0s to 7200s	
	Alarm	0s to 7200s	
Response time		2 or 8s (depending on filtering)	
Filtering		2, 20 or 40s	
Intermittent fault capture		Yes	
Self test	Automatic	Every 5 hours	
	Manual	Yes	
Input	Injection inhibition	Yes, settable as NO or NC contact	
Output relay	Quantity	2	
	Type de contact	Changeover	
	Breaking capacity AC	250V / 3A	
	Breaking capacity DC	48V / 1A, 3mA min. load	
	Setting	Failsafe or standard or mirror	
Communication port		Modbus RS485	
Operating Modes		Medium Voltage	
Measurement voltage (peak)		20V, 40V, 60V, 80V	
Measurement current (peak)		500 μA, 1mA, 1.5mA, 2mA	
Measuring frequency		DC	
Internal resistance		40 KΩ	
Environment			
Protection degree	Front	IP54	
	Rear	IP20	
Overvoltage category		300 V/OVC3 / 600 V/OVC2	
Pollution degree		2	
Temperature strength	For operation	-25°C to +55°C	
	For storage	-40°C to +70°C	
Altitude max.		Up to 3000m	
Relative humidity		≤ 92%	
Conformally coated		No	
Human Machine Interface			
Multilingual interface	8 languages	En, Fr, Es, Po, Zh, It, De, Ru	
Others	Historical resistance log	Yes	
	Time stamped Event log	Yes	



Commercial reference

- IMDIFL12.
- IMDIFL12L.

Standards & certifications

- IEC61557-9 Ed.2014
- IEC61010-1 Ed.2010
- UL 61010-1 Ed.2012
- IEC61326-2-4 Ed.2012
- IEC60364-4-41 Ed.2005

Functions

- When associated with IM400 series, acts as Insulation Fault Locator, simultaneously for 12 feeders.
- Monitors the insulation to ground of each individual feeder.
- Detect an insulation fault according to the set alarm threshold.

Main features

- Power Supply: 100-440VAC/DC or 24-48VDC.
- One common alarm threshold for all feeders (Low, Medium or High).
- Fast response time: 5s.
- Filtering for highly disturbed power system.
- Intermittent insulation fault reporting.
- Insulation fault is displayed via 12 LED, one per feeder.
- Simple and user friendly human machine interface.
- Fast dedicated commissioning procedure.
- Simple installation: Stand alone device, no wire connection to the Insulation Monitor.
- Unlimited number of IFL12 in the same power system.

Application

- Ungrounded networks requiring automatic insulation fault location.
- Power Circuits networks, including power loads and power electronics such as speed drives, inverters, rectifiers, etc.
- Typical segments: Industry, Power generation, Marine, Railways, Airport, Oil&Gas, Mining, Water, heating & Cooling, Lifts, etc, requesting continuity of service even in case of earth insulation fault.
- Mobile insulation fault locator kit complementary to IFL.

Compatible auxiliaries

- Toroids: TA30, PA50, IA80, MA120, SA200, GA300, TOA80 & TOA120.
- Voltage adaptors: PHT1000.
- Earthing Impedance: ZX.
- Surge Limiter: Cardew C.
- Mobile insulation fault locator: XRM + probes.

Examples of architectures

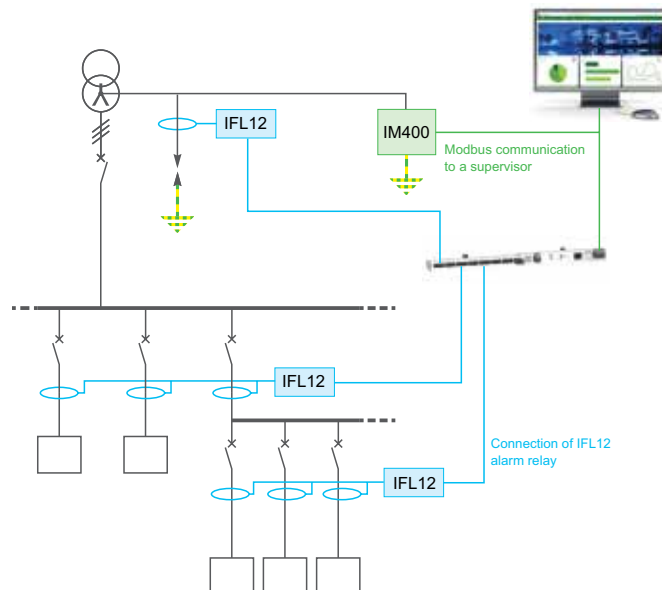

Vigilohm IFL12 / IFL12L Insulation Fault Locator

Physical Description

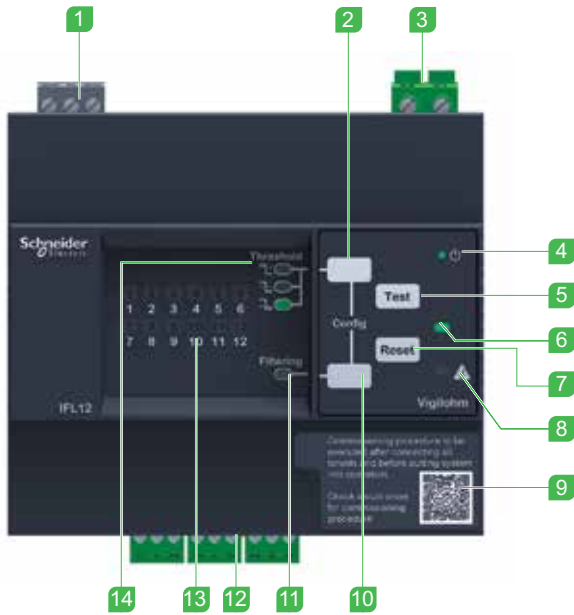

- 1 Alarm relay
- 2 Alarm threshold selection button
- 3 Auxillary power supply
- 4 Product status LED
- 5 Test button
- 6 No alarm LED
- 7 Reset button
- 8 Alarm LED
- 9 Peel off label
- 10 Filtering enable/disable button
- 11 Filtering enable/disable LED
- 12 12 toroid connections
- 13 12 channel LEDs
- 14 Low / Medium / High threshold LEDs
- 15 Gasket
- 16 Label
- 17 DIN mounting clip

Dimensions

Dimensions mm / (inch)

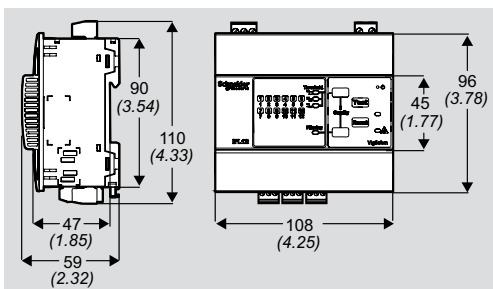

Cut-out for flush mount mm / (inch)

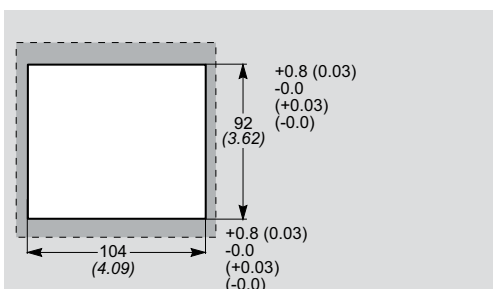

Minimum clearance between flush mounted devices mm / (inch)

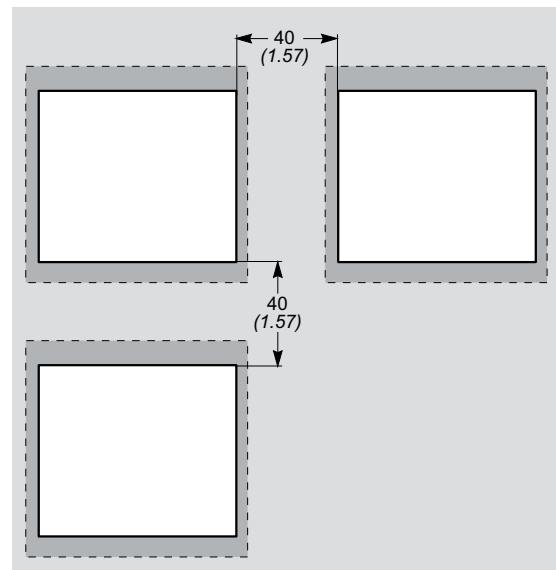

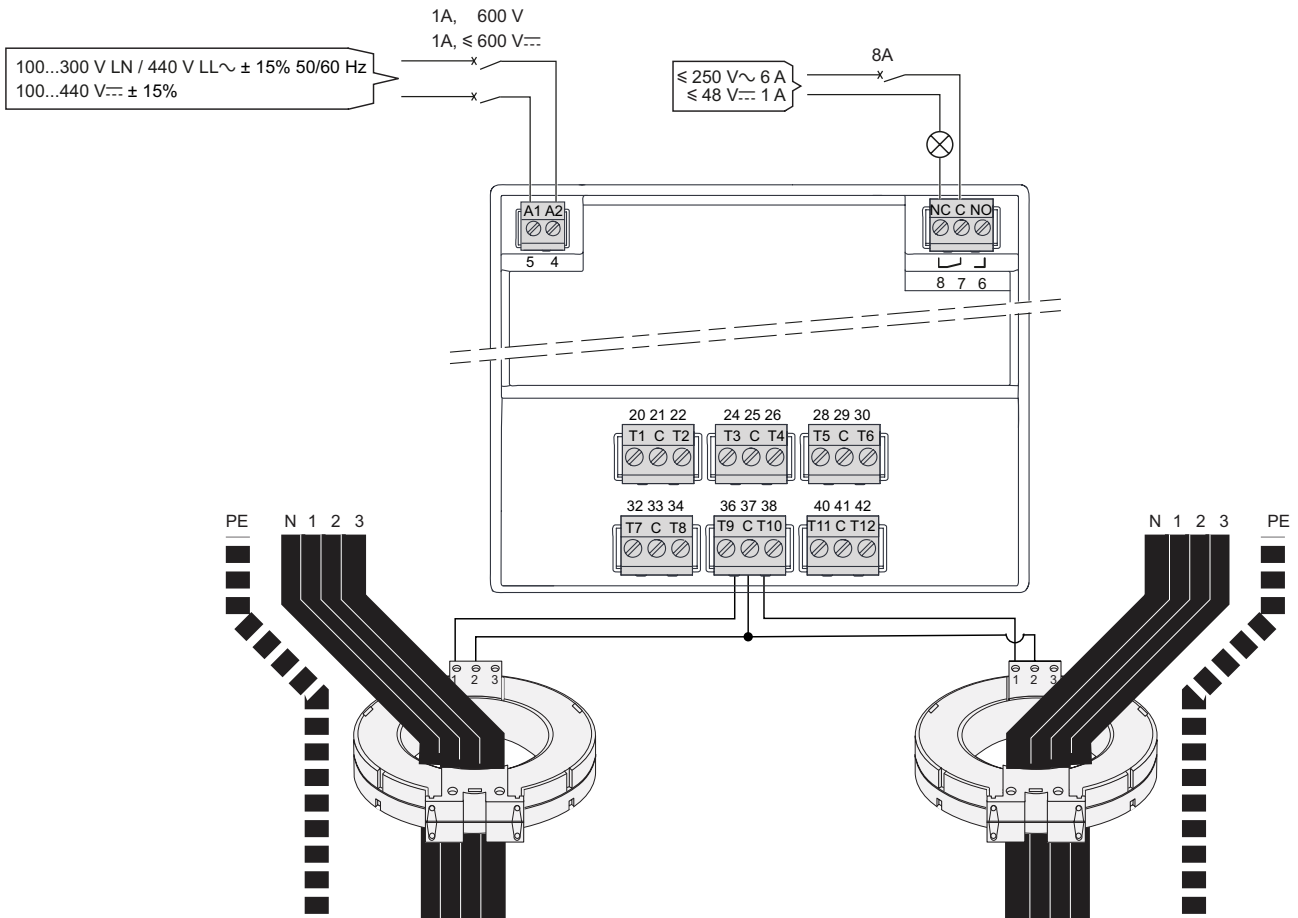

Vigilohm IFL12 / IFL12L Insulation Fault Locator

Connection

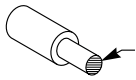
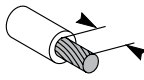
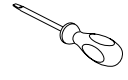

Note: Example of toroid connection to T9 and T10 is illustrated. Use similar connection for other toroids.

				
{T1, C, T2}, {T3, C, T4}, {T5, C, T6}, {T7, C, T8}, {T9, C, T10}, {T11, C, T12}	1 conductor - 1.5 mm ² (16 AWG) 2 conductors - 0.75 mm ² (18 AWG)	7mm (0.28 in) ± 1 mm (0.040 in)	∅ 2.5 mm (7/64 in)	0.22 - 0.25 Nm (1.9 - 2.2 in lb)
A1, A2	0.2 - 2.5 mm ² (24 - 14 AWG)	7mm (0.28 in) ± 1 mm (0.040 in)	∅ 3 mm (1/8 in)	0.5 - 0.6 Nm (4.4 - 5.3 in lb)
NC, C, NO	0.2 - 2.5 mm ² (24 - 14 AWG)	7mm (0.28 in) ± 1 mm (0.040 in)	∅ 3 mm (1/8 in)	0.5 - 0.6 Nm (4.4 - 5.3 in lb)

Vigilohm IFL12 / IFL12L

Insulation Fault Locator

General characteristics

Commercial name		IFL12	IFL12L
Type of network to monitor			
Max phase to phase voltage		≤1000VAC	
Max line voltage		≤1000VDC	
Network max capacitance		150μF	
Frequency		AC and DC networks	
Grounding arrangement		IT / HRG	
Power Supply			
Auxiliary supply voltage	Voltage	100-440VAC/DC	24-48VDC
	Frequency	50Hz - 60Hz - 400Hz (80-120VLN)	-
	Tolerance	+/-15%	
	Maximum consumption	<20VA <6W	<8W
	Recommended protection	1A	
Product Performances			
Number of Channels		12	
Range for insulation resistance	Reading	Not available	
Range for earth leakage capacitance	Reading	Not available	
Fault signaling thresholds	Alarm	High impedance, medium impedance or low impedance	
Settable alarm delay		Not available	
Polling (12 channels)		All channels simultaneously	
Response time		5s, 40s	
Intermittent fault capture		Yes	
Self test	Automatic	Yes	
	Manual	Yes	
Output relay	Quantity	1	
	Type de contact	Changeover	
	Breaking capacity AC	250VAC / 6A	
	Breaking capacity DC	48VDC / 1A, 3mA min. load	
	Setting	Standard	
Communication port		No	
Operating Modes	Power Circuit	Compatible	
	Control Circuit	Not compatible	
Environment			
Protection degree	Front	IP54	
	Rear	IP20	
Overvoltage category		300V OVC3 / 600V OVC2	
Pollution degree		2	
Temperature strength	For operation	-25°C to +55°C	
	For storage	-40°C to +85°C	
Altitude max.		up to 3000m	
Relative humidity		≤ 92%	
Human Machine Interface			
HMI		LED+Buttons	
Multilingual interface	8 languages	N.A.	
Others	Historical resistance log	No	
	Time stamped Event log	No	
Others characteristics			
Insulation Monitors compatible		IM400, IM400C, IM400L and former ranges: XM200, XM300, XML3xx	

Communicating Insulation Fault Locator



IFL12C



Commercial reference

- IMDIFL12C.

Standards & certifications

- IEC61557-9 Ed.2014
- IEC61010-1 Ed.2010
- UL 61010-1 Ed.2012
- IEC61326-2-4 Ed.2012
- IEC60364-4-41 Ed.2005



Functions

- When associated with IM400 series, acts as Insulation Fault Locator, simultaneously for 12 feeders.
- Monitors the insulation to ground of each individual feeder.
- Detect an insulation fault based to the set alarm threshold.
- Triggers an alarm via the output contact relay in case of insulation fault on any feeder and through the communication port.

Main features

- Power Supply: 100-440VAC/DC.
- One common alarm threshold for all feeders (Low, Medium or High).
- Fast response time: 5s.
- Filtering for highly disturbed system.
- Intermittent insulation fault reporting.
- Insulation fault is displayed on the LCD.
- Simple and user friendly human machine interface.
- Fast dedicated commissioning procedure.
- Simple installation: Stand alone device, no wire connection to the Insulation Monitor.
- User friendly LCD HMI in 8 languages.
- Communicate via Modbus RS485 to allow remote setting and report of alarms in the supervision system.
- Timestamped event log.
- No limitation regarding the number of IFL12C that can be installed in a system.

Application

- Ungrounded networks requiring automatic insulation fault location
- Power Circuits networks, including power loads and power electronics such as speed drives, inverters, rectifiers, etc...
- Typical segments: Industry, Power generation, Marine, Railways, Airport, Oil&Gas, Mining, Water, Heating & Cooling, Lifts, etc requesting continuity of service even in case of earth insulation fault.
- Mobile insulation fault locator kit complementary to IFL.

Compatible auxiliaries

- Toroids: TA30, PA50, IA80, MA120, SA200, GA300, TOA80 & TOA120.
- Voltage adaptors: PHT1000.
- Earthing Impedance: ZX.
- Surge Limiter: Cardew C.
- Mobile insulation fault locator: XRM + probes.
- Gateways and supervisions - Examples: Com'X 510, Link150, Smartlink, PME, PSO.

Examples of architectures

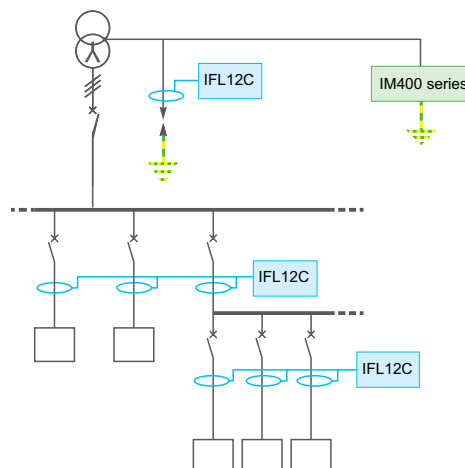

Vigilohm IFL12C

Communicating Insulation Fault Locator

Physical Description

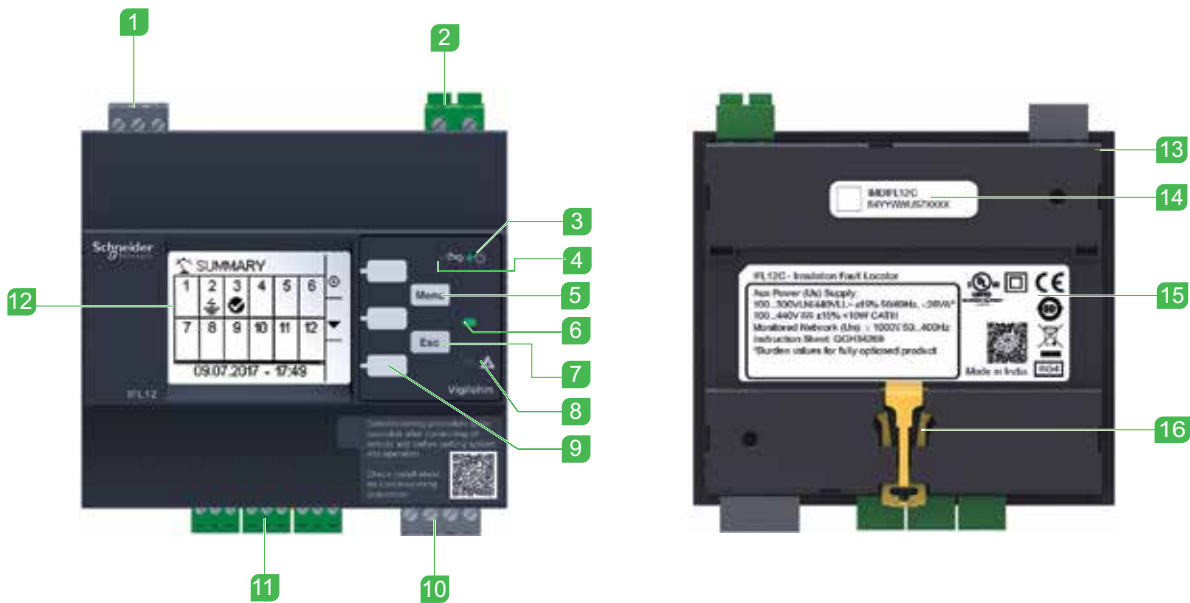

- 1 Alarm relay
- 2 Auxiliary power supply
- 3 Product status LED
- 4 Communication LED
- 5 Menu button
- 6 No alarm LED
- 7 Esc button
- 8 Alarm LED
- 9 Contextual menu buttons
- 10 RS-485 communication
- 11 12 toroid connections
- 12 LCD screen
- 13 Gasket
- 14 Commercial reference and manufacturing data
- 15 Label
- 16 DIN mounting clip

Dimensions

Dimensions mm / (inch)

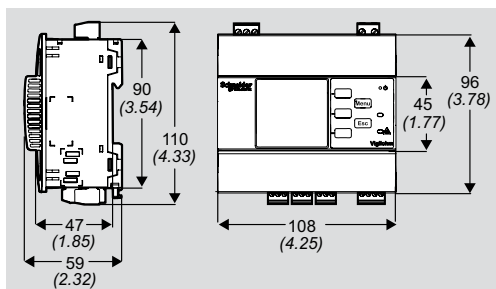

Cut-out for flush mount mm / (inch)

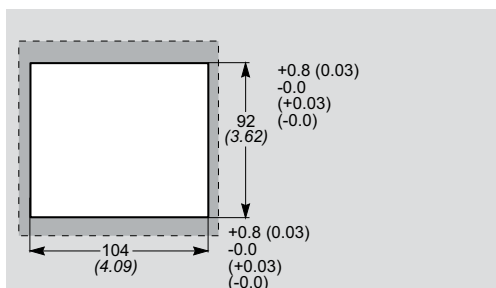

Minimum clearance between flush mounted devices mm / (inch)

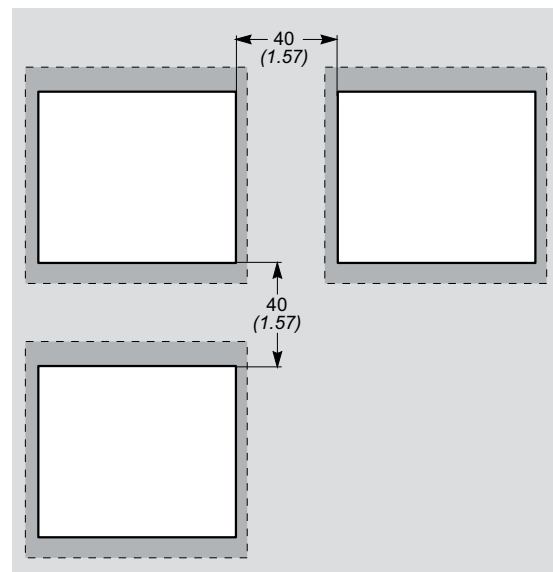

Vigilohm IFL12C Communicating Insulation Fault Locator

Connection

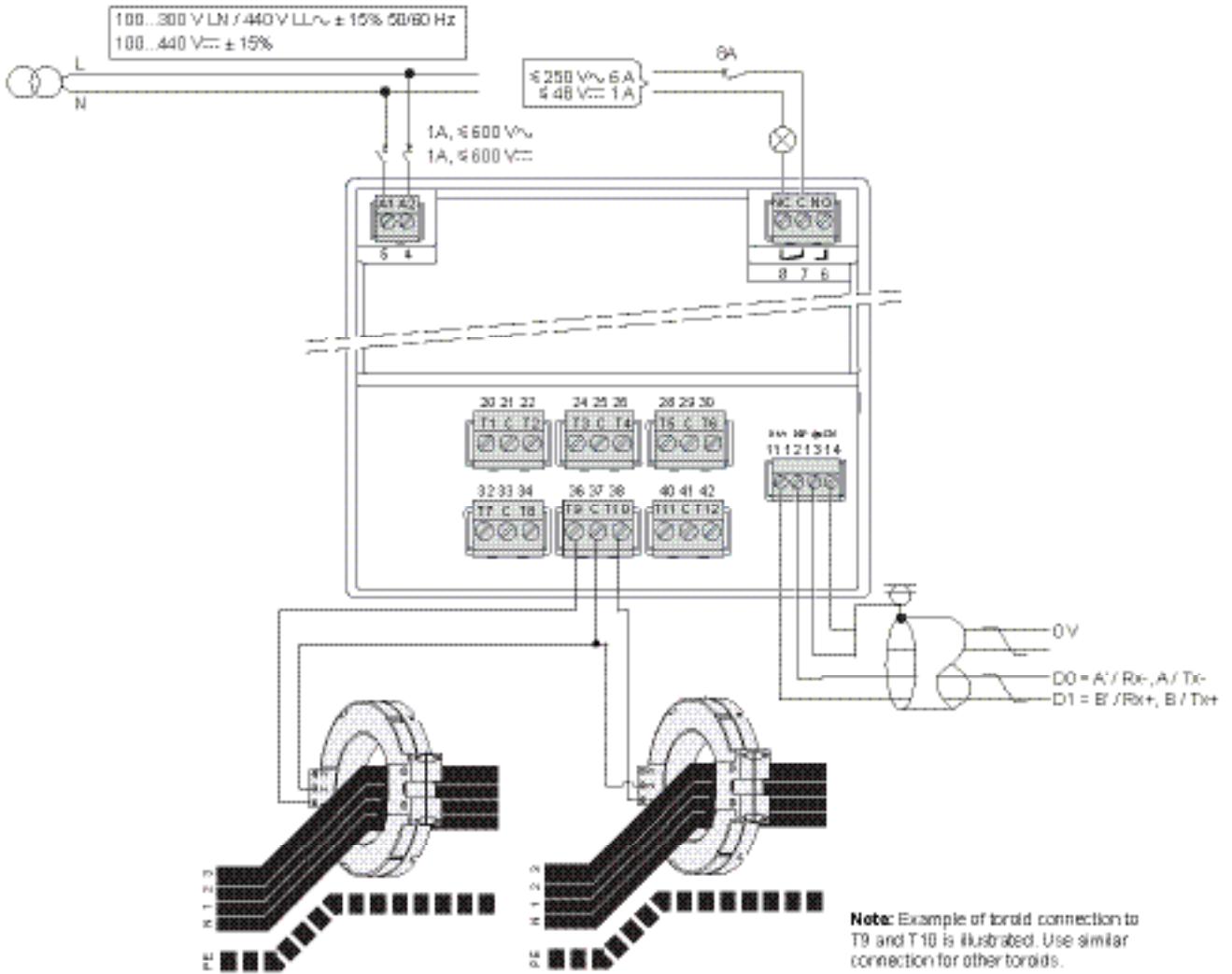

{T1, C, T2}, {T3, C, T4}, {T5, C, T6}, {T7, C, T8}, {T9, C, T10}, {T11, C, T12}	1 conductor - 1.5 mm ² (16 AWG) 2 conductors - 0.75 mm ² (18 AWG)	7mm (0.28 in) ± 1 mm (0.040 in)	∅ 2.5 mm (7/64 in)	0.22 - 0.25 Nm (1.9 - 2.2 in lb)
A1, A2	0.2 - 2.5 mm ² (24 - 14 AWG)	7mm (0.28 in) ± 1 mm (0.040 in)	∅ 3 mm (1/8 in)	0.5 - 0.6 Nm (4.4 - 5.3 in lb)
NC, C, NO	0.2 - 2.5 mm ² (24 - 14 AWG)	7mm (0.28 in) ± 1 mm (0.040 in)	∅ 3 mm (1/8 in)	0.5 - 0.6 Nm (4.4 - 5.3 in lb)
N/L, ⚬	0.82 - 3.31 mm ² (18 - 12 AWG)	7mm (0.28 in) ± 1 mm (0.040 in)	∅ 3 mm (1/8 in)	0.5 - 0.6 Nm (4.4 - 5.3 in lb)
+, -, ∅, C	0.13 - 0.82 mm ² (26 - 18 AWG)	7mm (0.28 in) ± 1 mm (0.040 in)	∅ 3 mm (1/8 in)	0.5 - 0.6 Nm (4.4 - 5.3 in lb)

Communicating Insulation Fault Locator

General characteristics

Commercial name		IFL12C
Type of network to monitor		
Max phase to phase voltage		≤1000VAC
Max line voltage		≤1000VDC
Network max capacitance		150μF
Frequency		AC and DC networks
Grounding arrangement		IT / HRG
Power Supply		
Auxiliary supply voltage	Voltage	100-440VAC/DC
	Frequency	50Hz - 60Hz - 400Hz (80-120VLN)
	Tolerance	+/-15%
	Maximum consumption	<26VA <10W
	Recommended protection	1A
Product Performances		
Number of Channels		12
Range for insulation resistance	Reading	Not available
Range for earth leakage capacitance	Reading	Not available
Fault signaling thresholds	Alarm	High impedance, medium impedance or low impedance
Settable alarm delay		Not available
Polling (12 channels)		All channels simultaneously
Response time		5s, 40s
Intermittent fault capture		Yes
Self test	Automatic	Yes
	Manual	Yes
Output relay	Quantity	1
	Type de contact	Changeover
	Breaking capacity AC	250VAC / 6A
	Breaking capacity DC	48VDC / 1A, 3mA min. load
	Setting	Failsafe or standard
Communication port		Modbus RS485
Operating Modes	Power Circuit	Compatible
	Control Circuit	Not compatible
Environment		
Protection degree	Front	IP54
	Rear	IP20
Overvoltage category		300V OVC3 / 600V OVC2
Pollution degree		2
Temperature strength	For operation	-25°C to +55°C
	For storage	-40°C to +85°C
Altitude max.		up to 3000m
Relative humidity		≤ 92%
Human Machine Interface		
HMI		LCD+Buttons
Multilingual interface	8 languages	En, Fr, Es, Po, Zh, It, De, Ru
Others	Historical resistance log	Not Available
	Time stamped Event log	Not Available
Others characteristics		
Insulation Monitors compatible		IM400, IM400C, IM400L and former ranges: XM200, XM300, XML3xx

Vigilohm IFL12MC / LMC / MCT / LMCT

Advanced Insulation Fault Locator



IFL12LMC



Commercial reference

- IMDIFL12MC.
- IMDIFL12LMC.
- IMDIFL12MCT.
- IMDIFL12LMCT.

Standards & certifications

- IEC61557-9 Ed.2014
- IEC61010-1 Ed.2010
- UL 61010-1 Ed.2012
- IEC61326-2-4 Ed.2012
- IEC60364-4-41 Ed.2005



Functions

- When associated with IM400 series, acts as Insulation Fault Locator, simultaneously for 12 feeders.
- Measure the insulation resistance to ground and the leakage capacitance of each individual feeder.
- Detect an insulation fault based to the set alarm threshold.
- Generate an alarm via the output contacts relay in case of insulation fault on any feeder and via the communication port.

Main features

- Power Supply 100-440VAC/DC or 24-48VDC.
- Each feeder has its own Alarm threshold set from 200Ω to 200KΩ.
- Fast response time: 5s.
- Filtering for highly disturbed power system.
- Intermittent insulation fault reporting.
- Large screen and interactive human-machine interface to ease operation & maintenance.
- Measures and displays each feeder's insulation resistance from 200Ω to 250KΩ, and leakage capacitance from 1μF to 15μF.
- Fast dedicated commissioning procedure.
- Simple installation: Stand alone device, no wire connection to the Insulation Monitor.
- User friendly LCD HMI in 8 languages.
- Communication to supervision via Modbus RS485 port, allowing remote configuration and reporting of real time data and alarms.
- Timestamped event log.
- Insulation and Capacitance measurement trending log and curves for preventive maintenance.
- Historical logging for preventive maintenance
- No limitation regarding the number of IFL12MC that can be installed in a system.
- Exists in tropicalized versions for harsh environments.

Application

- Ungrounded networks requiring automatic insulation fault location.
- Power Circuits networks, including power loads and power electronics such as speed drives, inverters, rectifiers, etc.
- Control Command networks, including sensitive loads such as PLCs, I/Os, sensors.
- Typical segments: Electrical Distribution, Industry, Power generation, Marine, Airport, Oil&Gas, Mining, Lifts, etc. requesting continuity of service even in case of earth insulation fault.
- Mobile insulation fault locator kit complementary to IFL.

Examples of architectures

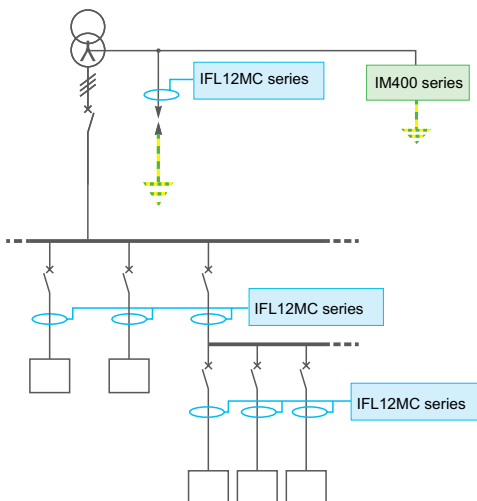

Compatible auxiliaries

- Toroids: TA30, PA50, IA80, MA120, SA200, GA300, TOA80 & TOA120.
- Voltage adaptors: PHT1000.
- Earthing Impedance: ZX.
- Surge Limiter: Cardew C.
- Mobile insulation fault locator: XRM + probes.
- Gateways and supervisions - Examples: Com'X 510, Link150, Smartlink, PME, PSO.

Vigilohm IFL12MC / LMC / MCT / LMCT

Advanced Insulation Fault Locator

Physical Description

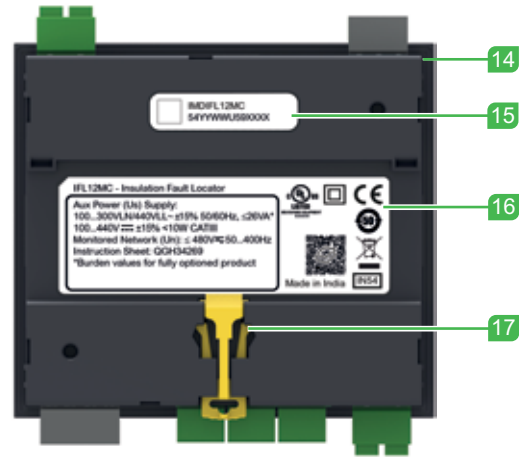
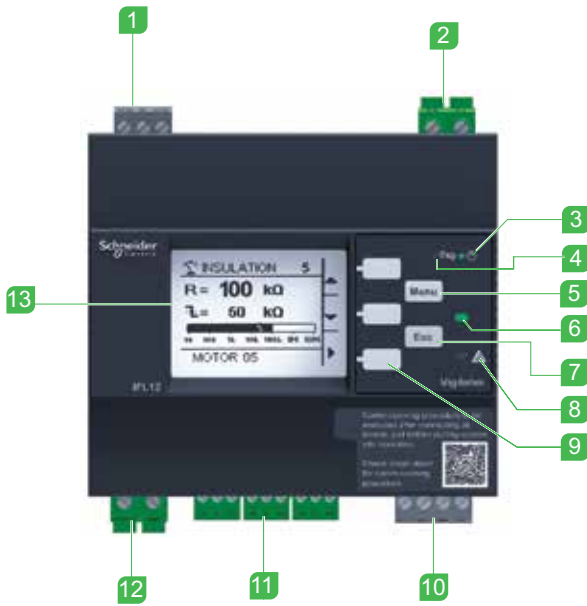

- 1 Alarm relay
- 2 Auxiliary power supply
- 3 Product status LED
- 4 Communication LED
- 5 Menu button
- 6 No alarm LED
- 7 Esc button
- 8 Alarm LED
- 9 Contextual menu buttons

- 10 RS-485 communication
- 11 12 toroid connections
- 12 Voltage input
- 13 LCD screen
- 14 Gasket
- 15 Commercial reference and manufacturing data
- 16 Label
- 17 DIN mounting clip

Dimensions

Dimensions mm / (inch)

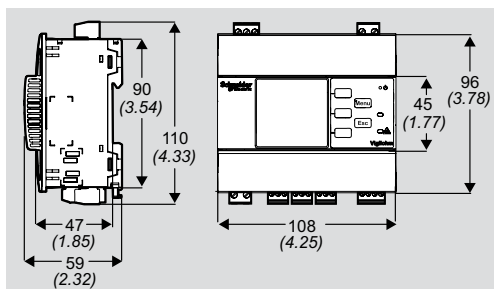

Cut-out for flush mount mm / (inch)

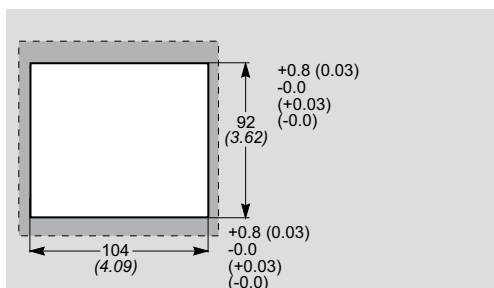

Minimum clearance between flush mounted devices mm / (inch)

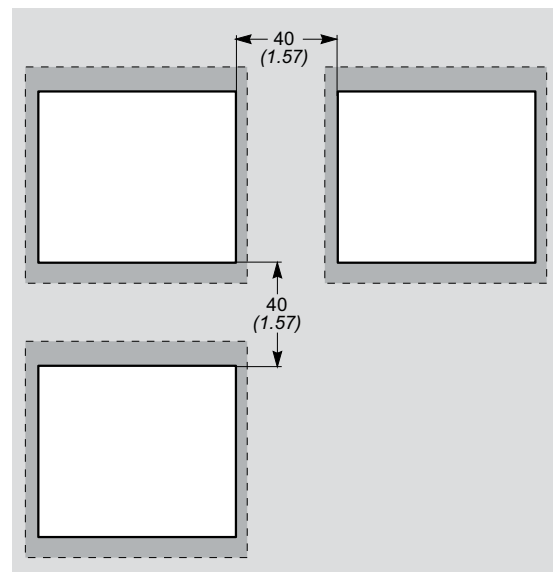

Vigilohm IFL12MC / LMC / MCT / LMCT

Advanced Insulation Fault Locator

Connection

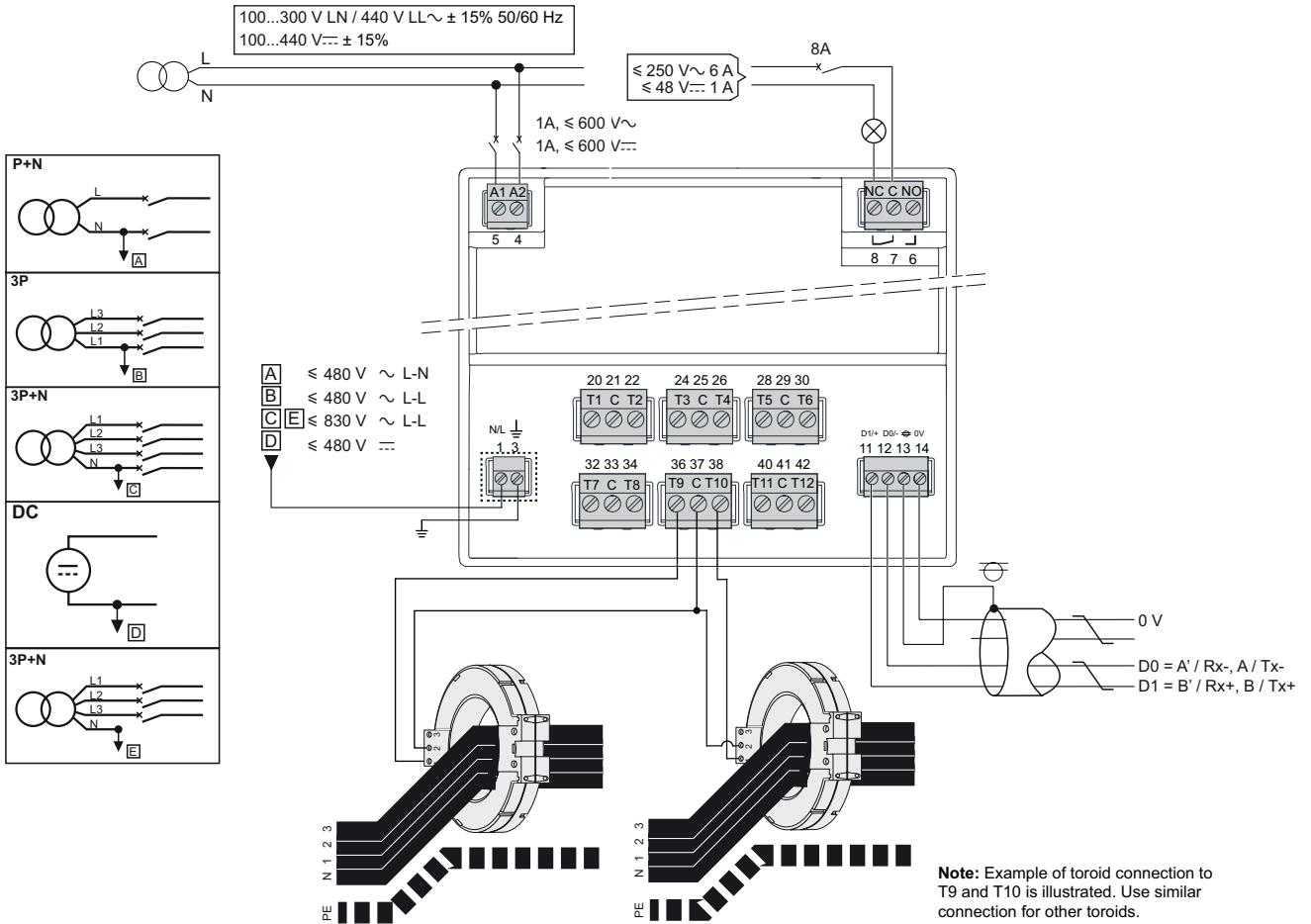

{T1, C, T2}, {T3, C, T4}, {T5, C, T6}, {T7, C, T8}, {T9, C, T10}, {T11, C, T12}	1 conductor - 1.5 mm ² (16 AWG) 2 conductors - 0.75 mm ² (18 AWG)	7mm (0.28 in) ± 1 mm (0.040 in)	∅ 2.5 mm (7/64 in)	0.22 - 0.25 Nm (1.9 - 2.2 in lb)
A1, A2	0.2 - 2.5 mm ² (24 - 14 AWG)	7mm (0.28 in) ± 1 mm (0.040 in)	∅ 3 mm (1/8 in)	0.5 - 0.6 Nm (4.4 - 5.3 in lb)
NC, C, NO	0.2 - 2.5 mm ² (24 - 14 AWG)	7mm (0.28 in) ± 1 mm (0.040 in)	∅ 3 mm (1/8 in)	0.5 - 0.6 Nm (4.4 - 5.3 in lb)
N/L, ⊥	0.82 - 3.31 mm ² (18 - 12 AWG)	7mm (0.28 in) ± 1 mm (0.040 in)	∅ 3 mm (1/8 in)	0.5 - 0.6 Nm (4.4 - 5.3 in lb)
+, -, ∅, C	0.13 - 0.82 mm ² (26 - 18 AWG)	7mm (0.28 in) ± 1 mm (0.040 in)	∅ 3 mm (1/8 in)	0.5 - 0.6 Nm (4.4 - 5.3 in lb)

Advanced Insulation Fault Locator

General characteristics

Commercial name		IFL12MC	IFL12LMC	IFL12MCT	IFL12LMCT
Type of network to monitor					
Max phase to phase voltage	Connected to neutral	≤ 830 VAC ⁽¹⁾			
	Connected to phase	≤ 480 VAC ⁽¹⁾			
Max line voltage		≤ 480 VDC ⁽¹⁾			
Network max capacitance		150µF			
Frequency		AC and DC networks			
Grounding arrangement		IT / HRG			
Power Supply					
Auxiliary supply voltage	Voltage	100-440VACDC	24-48VDC	100-440VACDC	24-48VDC
	Frequency	50Hz - 60Hz - 400Hz (80-120VLN)	-	50Hz - 60Hz - 400Hz (80-120VLN)	-
	Tolerance	+/-15%			
	Maximum consumption	<26VA <10W	<12W	<26VA <10W	<12W
	Recommended protection	1A			
Product Performances					
Number of Channels		12			
Range for insulation resistance	Reading	200Ω...250KΩ			
	Accuracy at 10 kΩ, 1 µF	10%			
Earth leakage capacitance	Reading	0.1µF...15µF			
	Accuracy at 10 kΩ, 1 µF	10%			
Fault signaling thresholds	Alarm	200Ω...200KΩ			
Settable alarm delays	Alarm	0..7200s			
Polling (12 channels)		All channels simultaneously			
Response time		5s, 40s, 400s			
Intermittent fault capture		Yes			
Self test	Automatic	Yes			
	Manual	Yes			
Output relay	Quantity	1			
	Type de contact	Changeover			
	Breaking capacity AC	250VAC / 6A			
	Breaking capacity DC	48VDC / 1A, 3mA min. load			
	Setting	Failsafe or standard			
Communication port		Modbus RS485			
Operating Modes	Power Circuit	Compatible			
	Control Circuit	Compatible			
Environment					
Protection degree	Front	IP54			
	Rear	IP20			
Overvoltage category		300V OVC3 / 600V OVC2			
Pollution degree		2			
Temperature strength	For operation	-25°C to +55°C		-25°C à +70°C	
	For storage	-40°C à+70°C		-40°C à+85°C	
Altitude max.		up to 3000m			
Relative humidity		≤ 92%		≤ 95%	
Tropicalization		No		Yes	
Human Machine Interface					
HMI		LCD+Buttons			
Multilingual interface	8 languages	En, Fr, Es, Po, Zh, It, De, Ru			
Others	Historical resistance log	Yes			
	Time stamped Event log	Yes			
Others characteristics					
Insulation Monitors compatible		IM400, IM400C, IM400L and former ranges : XM200, XM300, XML3xx			

⁽¹⁾ 1000VAC / 1000VDC if the IFL12MC and the IM400 are connected through a common PHT1000.

Insulation Fault Locator for Healthcare facilities



IFL12H



Commercial reference

- IMDIFL12H.

Standards & certifications

- IEC61557-9 Ed.2014
- IEC61010-1 Ed.2010
- UL 61010-1 Ed.2012
- IEC61326-2-4 Ed.2012
- IEC60364-7-710 Ed.2002

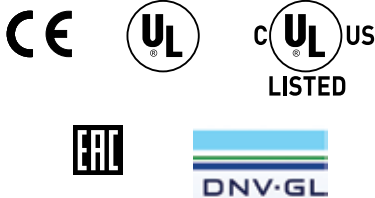

Functions

- When associated with IM10-H, IM15H or IM20-H, monitors simultaneously up to 12 feeders.
- Measure the insulation resistance to ground of each individual feeder.
- Detect an insulation fault based on the set alarm threshold.
- Generate an alarm via the output contacts relay in case of insulation fault on any feeder and via the communication port.

Main features

- Power Supply 110...230 VAC and 125...250 VDC.
- Each feeder has its own alarm threshold set from 50KΩ to 200KΩ .
- Fast response time: 5s.
- Intermittent insulation fault reporting.
- Large screen and interactive human-machine interface to ease operation & maintenance.
- Displays product status according to standard.
- Measures and displays each feeder's insulation resistance from 200Ω to 250KΩ.
- Fast dedicated commissioning procedure.
- Simple installation: Stand alone device, no wire connection to the Insulation monitor.
- User friendly LCD HMI in 8 languages.
- Communication to supervision via Modbus RS485 port, allowing remote configuration and reporting of real time data and alarms.
- Timestamped event log.
- No limitation regarding the number of IFL12H that can be installed in a system.

Application

- For Medical premises such as operating theaters, intensive care units, recovery rooms, designed as per IEC60364-7-710, where ungrounded networks are used and where automatic insulation fault location is required.
- Strongly recommended in networks where a medical IT system is used to supply multiple rooms or locations

Compatible auxiliaries

- Vigilohm Toroids.
- Gateways and supervisions - Examples: Link150, Smartlink, PME, EBO.
- Remote Displays: Operating Theater Display.

Examples of architectures

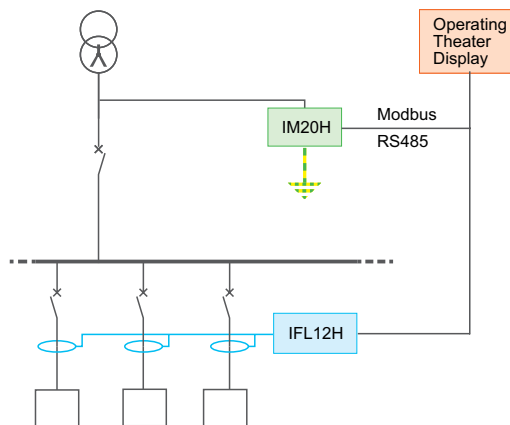

Insulation Fault Locator for Healthcare facilities

Physical Description

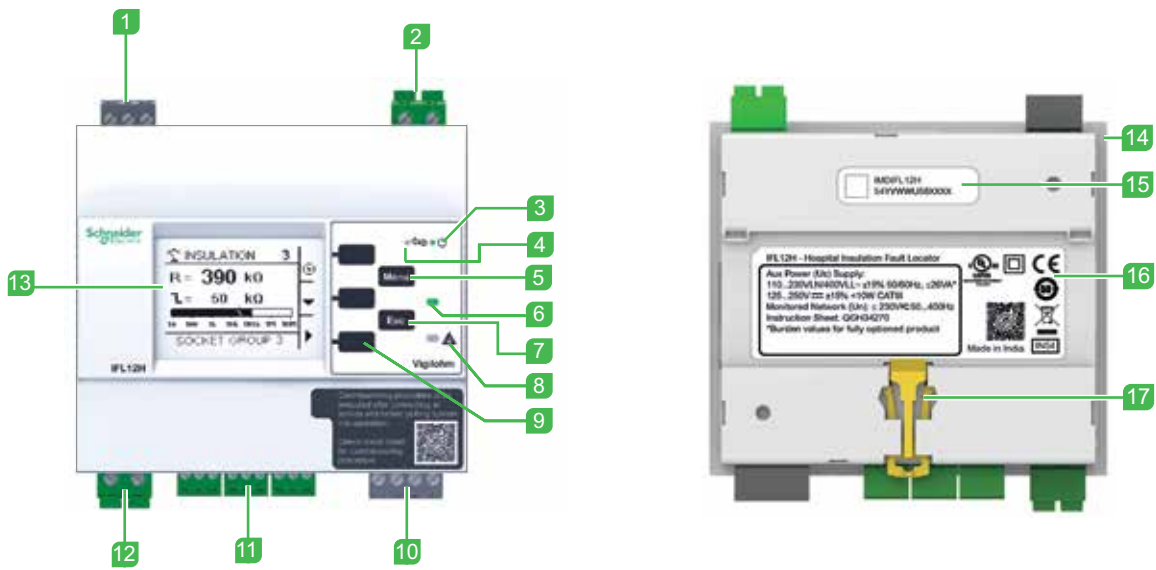

- 1 Alarm relay
- 2 Auxiliary power supply
- 3 Product status LED
- 4 Communication LED
- 5 Menu button
- 6 No alarm LED
- 7 Esc button
- 8 Alarm LED
- 9 Contextual menu buttons
- 10 RS-485 communication
- 11 12 toroid connections
- 12 Voltage input
- 13 LCD screen
- 14 Gasket
- 15 Commercial reference and manufacturing data
- 16 Label
- 17 DIN mounting clip

Dimensions

Dimensions mm / (inch)

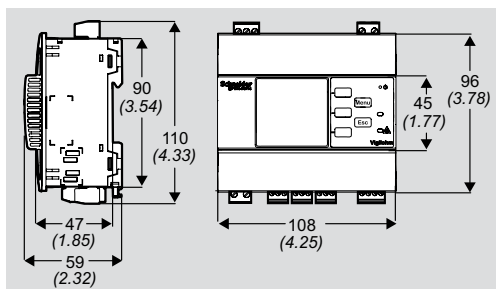

Cut-out for flush mount mm / (inch)

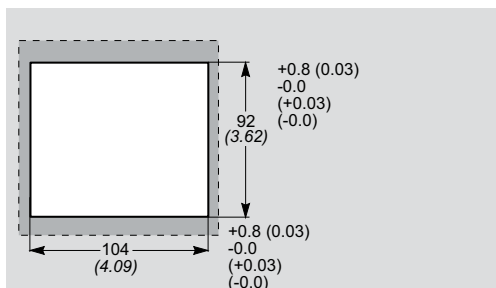

Minimum clearance between flush mounted devices mm / (inch)

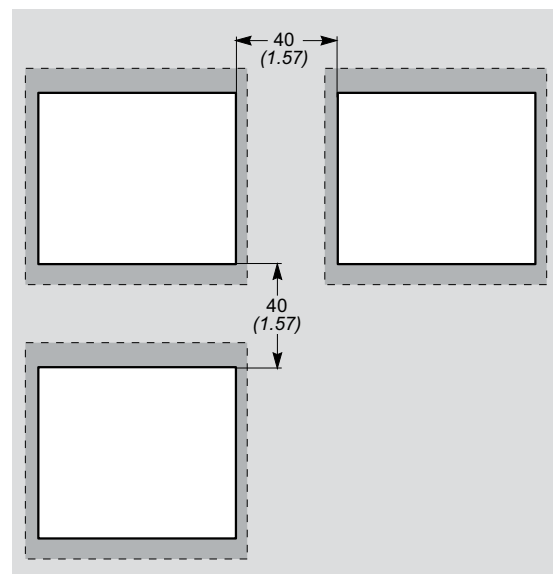

Vigilohm IFL12H Insulation Fault Locator for Healthcare facilities

Connection

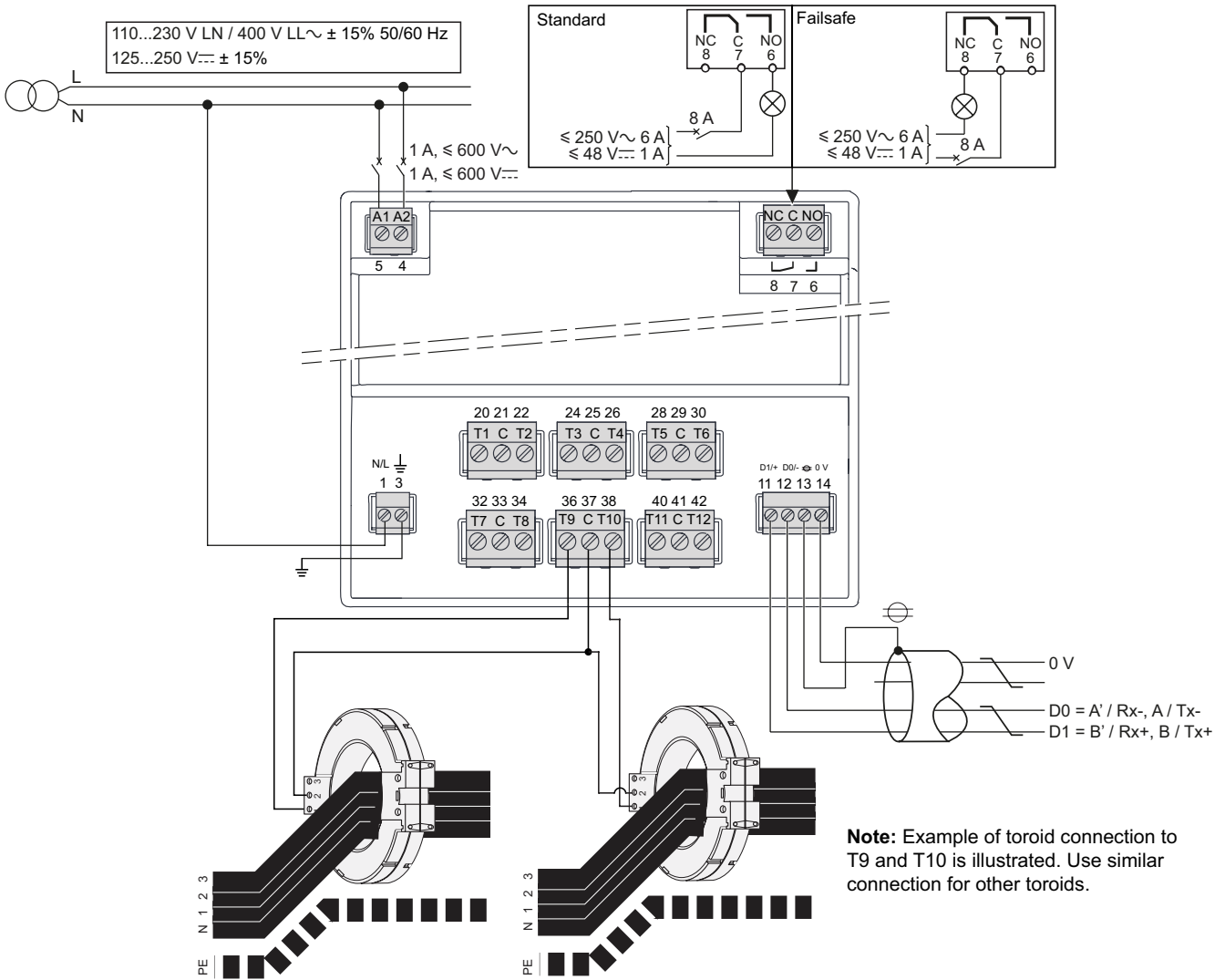

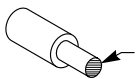
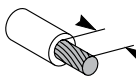
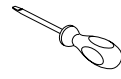
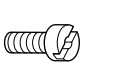
				
{T1, C, T2}, {T3, C, T4}, {T5, C, T6}, {T7, C, T8}, {T9, C, T10}, {T11, C, T12}	1 conductor - 1.5 mm ² (16 AWG) 2 conductors - 0.75 mm ² (18 AWG)	7mm (0.28 in) ± 1 mm (0.040 in)	∅ 2.5 mm (7/64 in)	0.22 - 0.25 Nm (1.9 - 2.2 in lb)
A1, A2	0.2 - 2.5 mm ² (24 - 14 AWG)	7mm (0.28 in) ± 1 mm (0.040 in)	∅ 3 mm (1/8 in)	0.5 - 0.6 Nm (4.4 - 5.3 in lb)
NC, C, NO	0.2 - 2.5 mm ² (24 - 14 AWG)	7mm (0.28 in) ± 1 mm (0.040 in)	∅ 3 mm (1/8 in)	0.5 - 0.6 Nm (4.4 - 5.3 in lb)
N/L, ⚡	0.82 - 3.31 mm ² (18 - 12 AWG)	7mm (0.28 in) ± 1 mm (0.040 in)	∅ 3 mm (1/8 in)	0.5 - 0.6 Nm (4.4 - 5.3 in lb)
+, -, ∅, C	0.13 - 0.82 mm ² (26 - 18 AWG)	7mm (0.28 in) ± 1 mm (0.040 in)	∅ 3 mm (1/8 in)	0.5 - 0.6 Nm (4.4 - 5.3 in lb)

Insulation Fault Locator for Healthcare facilities

General characteristics

Commercial name		IFL12H
Type of network to monitor		
Max phase to neutral voltage		≤ 230 VAC +15 %
Max line voltage		≤ 230 VDC +15 %
Frequency		50/60Hz
Grounding arrangement		Medical IT / ungrounded
Power Supply		
Auxiliary supply voltage	Voltage	110...230 VAC and 125...250 VDC
	Frequency	50-60 Hz
	Tolerance	+/-15%
	Maximum consumption	<26VA <10W
	Recommended protection	1A
Product Performances		
Number of Channels		12
Range for insulation resistance	Reading	200Ω...250KΩ
	Accuracy at 10 kΩ, 1 μF	10%
Fault signaling thresholds	Alarm	50K...200KΩ
Polling (12 channels)		All channels simultaneously
Response time		5s
Intermittent fault capture		Yes
Self test	Automatic	Yes
	Manual	Yes
Output relay	Quantity	1
	Type de contact	Changeover
	Breaking capacity AC	250VAC / 6A
	Breaking capacity DC	48VDC / 1A, 3mA min. load
	Setting	Failsafe or standard
Communication port		Modbus RS485
Environment		
Protection degree	Front	IP54
	Rear	IP20
Overvoltage category		300V OVC3 / 600V OVC2
Pollution degree		2
Temperature strength	For operation	-25°C to +55°C
	For storage	-40°C to +85°C
Altitude max.		up to 3000m
Relative humidity		≤ 92%
Human Machine Interface		
HMI		LCD+Buttons
Multilingual interface	8 languages	En, Fr, Es, Po, Zh, It, De, Ru
Others	Time stamped Event log	Yes
Others characteristics		
Insulation Monitors compatible		IM10-H, IM15H, IM20-H



XGR, XRM, Probes

Vigilohm XGR, XRM and Probes Mobile Fault Location



Functions

- The mobile fault location kit allows to manually locate an insulation fault on the ungrounded network, after the fault has been signaled by the Insulation Monitor
- It can be used for the location of low impedance faults
- Continuity of service is kept on the network during the operation of fault location with this kit
- It can come as a complement to the permanent Insulation Fault Locators; to come as close as possible to the network item causing the insulation fault.

Main features

- The mobile fault location kit includes a receiver: the XRM, to which a current probe is connected in order to perform measurements on each feeder
- 3 diameters of probes are available: 12mm (XP15), 50mm (XP50) and 100mm (XP100), adapted to the various cable sizes in the network.

Compatible devices

- The XRM measurement are based on either:
 - The injection component coming from a Vigilohm IM400, XM300, XML3xx or XM200
 - Or on the injection component of the XGR generator.
 - The XGR generator should be connected on the network in order to use the mobile kit if the insulation monitor is an IM9, IM10 or IM20. XGR injects a 2,5Hz signal compatible with the use of the mobile fault location kit.
- The XGR generator is not required if the insulation monitor on the network is an IM400, XM300, XML3xx or XM200
- A case can be purchased to easily store all components of the kit

Application

- The mobile fault location kit can be used on typical segments such as Industry, Power generation, Marine, Railways, Airport, Oil&Gas, Mining, Water, Heating & Cooling, lifts, ...requesting continuity of service even in case of earth insulation fault
- It cannot be used in critical rooms of medical premises that are in use

Commercial reference

- 50278: XRM
- 50281: XGR 115/127 V AC
- 50282: XGR 220/240 V AC
- 50283: XGR 380/415 V AC
- 50285: Empty case
- 50310: Complete kit, including 220/240V XGR
- 50494: XP15 probe
- 50498: XP50 probe
- 50499: XP100 probe

Standards & certifications

- IEC61557-8 Ed.2014
- IEC61557-9 Ed.2014
- IEC61010-1 Ed.2010
- UL 61010-1 Ed3.2012
- IEC61326-4 Ed.2012

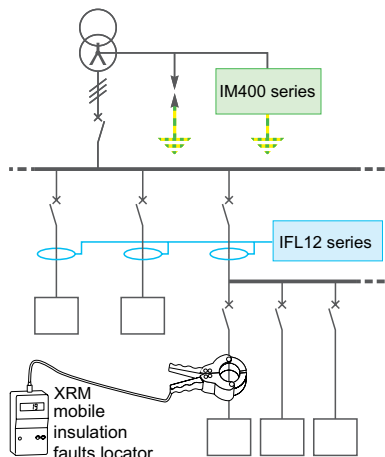

Physical Description

XRM Receiver

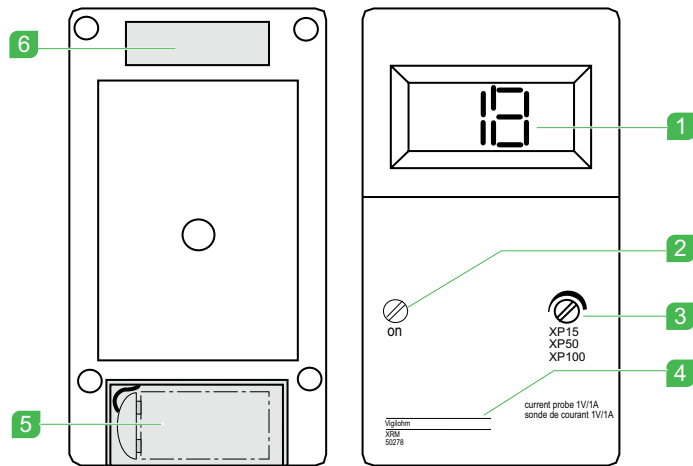

- 1 Reading indicator
- 2 ON pushbutton
- 3 Sensitivity adjustment (calibration)
- 4 Reference
- 5 Power supply 1 battery IEC 9V type PP3 or 6LR61 (alkaline) not supplied
- 6 Identification plate

Probes

XP15 probe

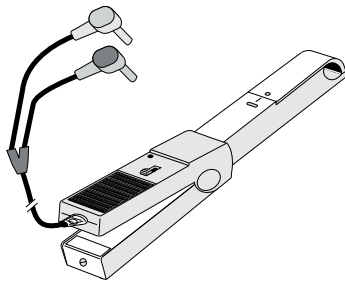

XP50 probe

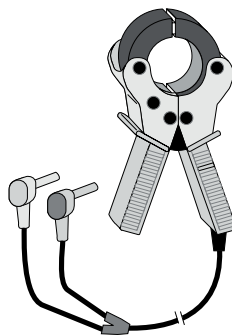

XP100 probe

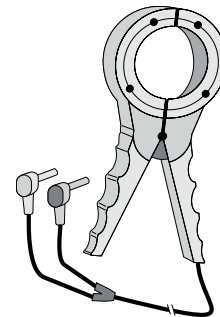

XGR Generator

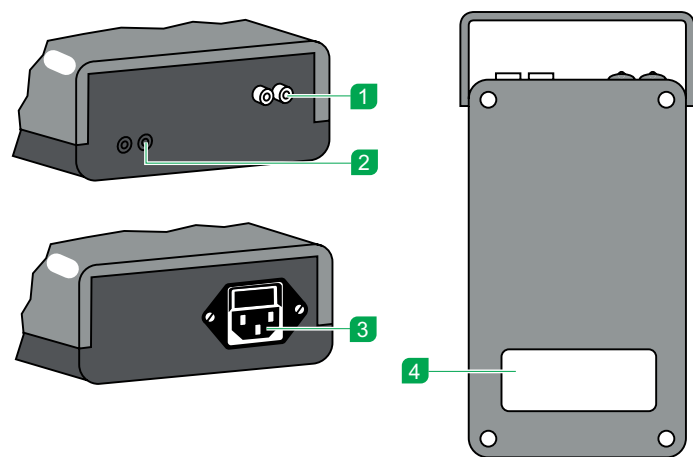

- 1 Injection output.
- 2 Presence of injection.
- 3 Power supply plug.
- 4 Identification plate.

Dimension

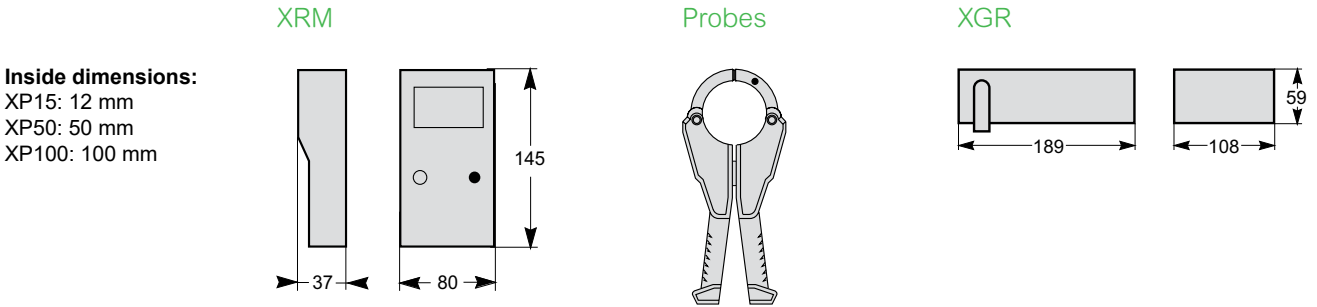

Operation

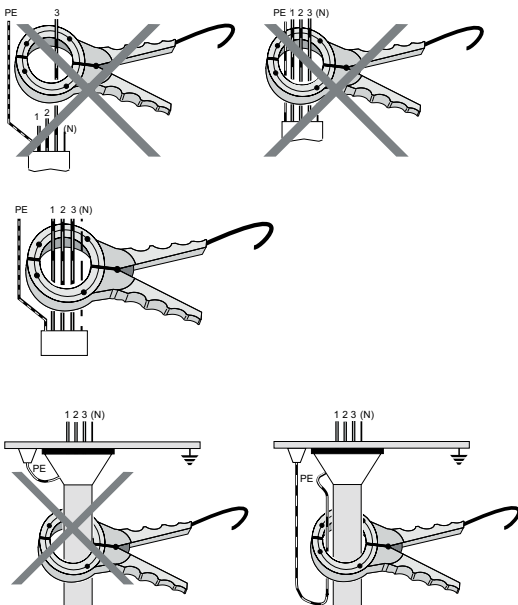

How to connect the probe for measurements?

1. The insulation monitor detects an insulation fault on the ungrounded network
2. If the network includes Insulation Fault locators, they will provide an indication of the feeder where the insulation fault is located
3. The mobile fault location kit will be used to get closer to the insulation fault. If the insulation monitor is not an IM400 / XM300 / XML3xx / XM200, the XGR should be connected to the network
4. The XRM with probe must be calibrated: being connect as close as possible to the IM400 / XM300 / XML3xx / XM200 and using the calibration button to display the value: 18
5. XRM and probe are now ready to be used. Ensure all active conductors are included in the probe, excluding the PE (figure on the right).
6. A higher value displayed by the XRM for a feeder indicates the fault is downstream this feeder. On large networks, a recalibration of the XRM receiver can be performed to increase its sensitivity (set the value back at 18 once the faulty portion of network has been confirmed)

Refer to Instruction Sheet for full details

General characteristics

Type of installation to be monitored			
General			
With XGR: Max ph-ph voltage with XGR connected to neutral			≤ 600 VAC
With XGR: Max ph-ph voltage with XGR connected to phase			≤ 440 VAC
With XGR: Max voltage for DC networks:			≤ 500 VDC
Max ph-ph voltage withstand by the probes			600V AC or DC
Frequency			AC or DC networks
Grounding arrangement			IT networks
Power Supply			
Auxiliary supply voltage	XGR	Voltage	115/127V AC or 220/240V AC or 380/415V AC
		Frequency	45-440Hz
		Max consumption	15 VA
	XRM	Power supply	1 battery IEC 9V type PP3 or 6LR61
Product Performances			
Product performances	XGR	Maximum current injected	2.5mA
		Measurement frequency	2.5Hz
		Internal resistance	40kOhms



Toroids

Earth leakage current detectors



A type closed toroid: PA30.

A type closed toroid: MA120.



A type closed toroid: IA80.

OA type split toroid: TOA80.

Functions

- These toroids are used with the Vigilohm Insulation Fault Locators for the location and measurement of insulation faults on IT systems.
- They measure the injected component from the Vigilohm Insulation Monitor and transmit a proportional signal to the associated Fault Locator.
- Closed toroids (type A) are suitable for new installations and extensions.
- Split toroids (type OA) are suitable for renovated installations and extensions.

Compatibility

- These toroids are compatible with all Vigilohm Insulation Fault Locators: IFL12, IFL12C, IFL12MC, IFL12H.
- Previous Vigilohm Insulation Fault Locators are also compatible with these toroids: XD312H (compatible with TA30), XD301, XD312, XD308C, XL308, XL316, XML308, XML316
- To confirm compatibility of toroids with older products, contact your technical support.

Installation

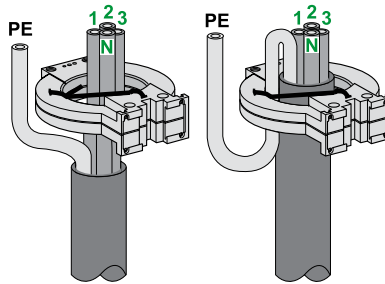

Use with a Vigilohm isolation fault locator:

- On an AC network, the toroid must include all phases (and the neutral if it is distributed)
- On a DC network, the toroid must include both polarities
- The toroid must not include the PE conductor
- The direction of the toroid does not matter

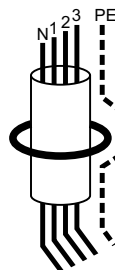

Line overcurrent immunity

Line overcurrents, due to motor starting or transformer powering, can cause an unintentional fault detection. Several simple precautions can be taken to avoid this inconvenience when combined, their efficiency is increased:

- Place the toroid on a straight part of the cable
- Center the cable in the toroid
- Use a toroid with a diameter significantly larger than that of the through cable ($1.4 \times \varnothing$)

Under severe operating conditions, the use of a mild steel sleeve placed around the cable in the core greatly improves immunity:

- Mild steel strip 1/10 mm thick to be wrapped several times around the cable that passes through the toroid (minimum thickness 1 mm).

Characteristics of the connection between fault locator and toroid:

- resistance $\leq 3 \Omega$
- wire cross-section: from 0.75 mm² to 1.5 mm².
- Max. length : 100 m.

Commercial reference

- TA30: 50437
- PA50: 50438
- IA80: 50439
- MA120: 50440
- SA200: 50441
- GA300: 50442
- TOA80: 50420
- TOA120: 50421

Standards & certifications

- IEC61010-1 Ed.2010
- UL 61010-1 Ed3.2012
- IEC61326-4 Ed.2012



Earth leakage current detectors

Connection of toroids

TA30 and PA50 toroids

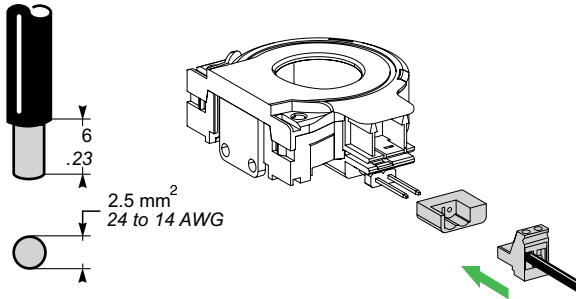

IA80, MA120, SA200 and GA300 toroids

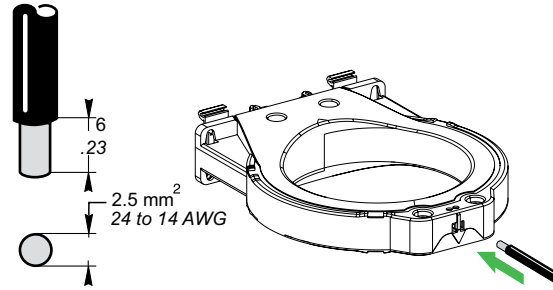

TOA80 and TOA120 toroid

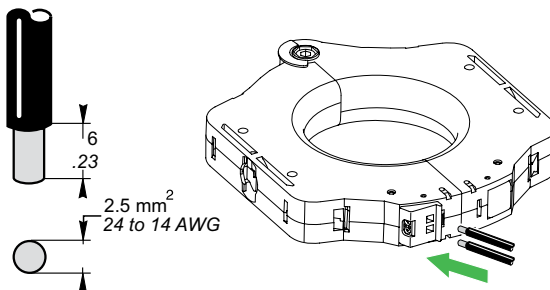

terminal 3 not used for toroid wiring

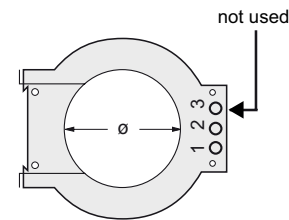

Mounting examples for Type A toroids

On rail Ø30 to Ø80 mm



On plate or section Type A Ø30 to Ø200 mm



On cable Ø120 to Ø300 mm



Dimensions

TA30 and PA50

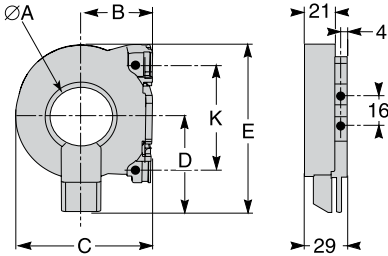

Type	Dimensions (mm)					
	ØA	B	C	D	E	F
TA30	9.4	32.5	63	44	74.5	50
PA50	50.4	45	88	57	100	60

IA80, MA120, SA200, GA300 Toroids

IA80 and MA120

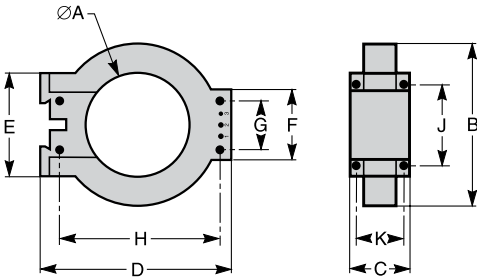

SA200 and GA300

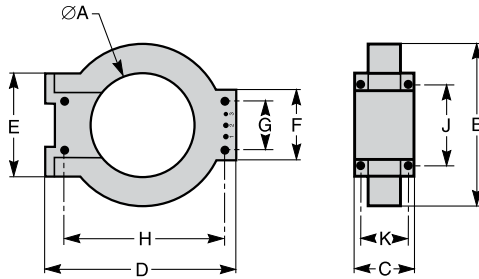

Type	Dimensions (mm)									
	ØA	B	C	D	E	F	G	H	J	K
IA80	80	122	44	150	80	55	40	126	65	35
MA120	118	164	39	190	140	-	-	163	125	30
SA200	196	256	46	274	120	90	60	254	104	37
GA300	291	360	46	390	120	90	60	369	104	37

TOA80 and TOA120 Toroids

TOA80

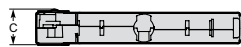

TOA120

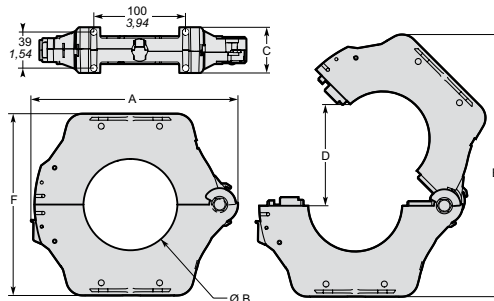

Type	Dimensions (mm)					
	A	B	C	D	E	F
TOA80	177	80	28	108	235	156
TOA120	225	120	50	150	303	205

Earth leakage current detectors

General characteristics

Commercial name	A type closed toroid		TOA type split toroid	
General characteristics				
Insulation voltage U_i	1000 V			
Operating-temperature range	- 35 °C / +70 °C			
Storage-temperature range	-55 °C / +85 °C			
Degree of protection	IP30 (connections IP20)			
Electrical characteristics				
Transformation ratio	1/1000			
Overvoltage category	4			
Rated impulse withstand voltage U_{imp} (kV)	12			
Mechanical characteristics				
Type of sensor	Dimensions Ø (mm)	Weight (kg)	Dimensions Ø (mm)	Weight (kg)
TA30 toroid	Ø 30	0.120	-	-
PA50 toroid	Ø 50	0.200	-	-
IA80 toroid	Ø 80	0.420	-	-
MA120 toroid	Ø 120	0.450	-	-
SA200 toroid	Ø 200	1.320	-	-
GA300 toroid	Ø 300	2.280	-	-
TOA80 toroid	-	-	80	0.9
TOA120 toroid	-	-	120	1.5
Mounting				
DIN rail mounting	TA30, PA50, IA80, MA120, SA200		TOA80, TOA120	
Plain, slotted or profiled plate	IA80, MA120, SA200, GA300		TOA80, TOA120	
Environment				
Damp heat, equipment not in service (IEC 60068-2-30)	28 cycles +25 °C / +55 °C / RH 95 %			
Damp heat, equipment in service (IEC 60068-2-56)	48 hours, environment category C2			
Salt mist (IEC 60068-2-52)	KB test, severity 2			
Degree of pollution (IEC 60664-1)	3			

Vigilohm HRP Hospital remote panel



HRP



Commercial reference

- 50168.

Standards & certifications

- IEC61010-1 Ed.2010
- UL 61010-1 Ed3.2012
- IEC61326-4 Ed.2012
- IEC60364-7-710 Ed.200
- IEC61557-8
- IEC60601-1



Functions

The HRP (Hospital Remote Panel) is an interface to be installed in a medical critical room such as an operating theater. It will inform the medical staff in real time about

- The existence of an insulation fault within the medical room
- The existence of an electrical fault due to a transformer overload or overheat

The HRP also allows to easily trigger the regular insulation test required by the IEC 60364-7-710 standard.

Main Features

The HRP includes the following:

- An indicator for insulation fault (yellow)
- An indicator for electrical fault (red)
- An indicator for Correct operation signal light (green)
- A push button to trigger an insulation test (an insulation fault of 39 kΩ is generated)
- A push button to stop the alarm buzzer. Alarm volume can be adjusted from the HRP.

Application

Critical medical premises as per IEC 60364-7-710, such as operation theaters, intensive care units, recovery rooms.

Compatible auxiliaries

The HRP works in association with an insulation monitor such as IM10-H, IM15H, IM20-H.

Dimensions (mm)

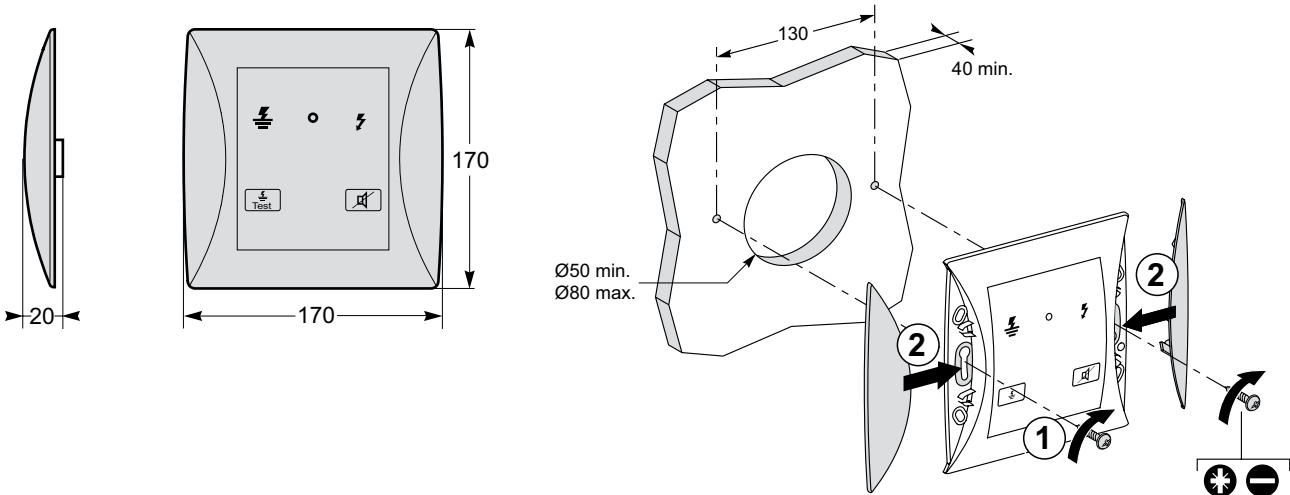

Physical Description

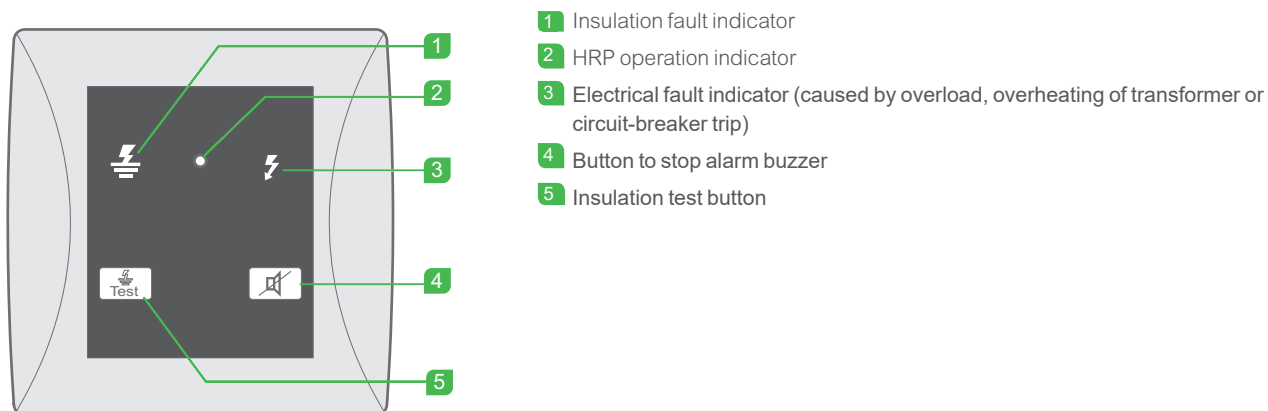

General characteristics

Commercial name		HRP
Mechanical characteristics		
Weight		0.5 kg
Case	Plastic	Vertical mounting
Degree of protection		IP54
		IK08
Dimensions	Height	170 mm
	Width	170 mm
	Depth	20 mm
Buzzer	Factory setting	80 db
Electrical characteristics		
Auxiliary supply voltage	24 V DC	65 mA
Environment		
Operating temperature		0 °C to 40 °C
Storage temperature		-25 °C to +70 °C
Maximum relative humidity		90 %
Altitude		2000 m



Magelis

Operating Theater Display



Commercial reference

- IMDLRDH

Standards & certifications

- IEC61010-1 Ed.2010
- UL 61010-1 Ed3.2012
- IEC61326-4 Ed.2012
- IEC60364-7-710 Ed.2002

Functions

The OTD (Operating Theater Display) is an interface to be installed in a medical critical room such as an operating theater. It will inform the medical staff in real time about

- The existence of an insulation fault within the medical room, and its location
- The existence of an electrical fault due to a transformer overload or overheat
- The trip of circuit breakers
- The status of medical gas or UPS.

The HRP also allows to easily trigger the regular insulation test required by the IEC 60364-7-710 standard.

Main Features

- Simple and intuitive human machine interface, informing the medical staff about the status of the medical room
- Messages shown on the OTD can be customized to display specific instructions to the medical staff and ease the understanding of information and actions to take
- The OTD includes a buzzer to provide a sound signal in case of alarm. The buzzer can be stopped from the OTD.
- The OTD is based on a Magelis reference HMISCU8A5.

Application

Critical medical premises as per IEC 60364-7-710, such as operation theaters, intensive care units, recovery rooms...

Compatible products

The OTD works in association with

- Insulation Monitor: IM20-H
- Insulation Fault Locator: IFL12H (up to 4 IFL12H can be connected to an OTD)
- Smartlink to retrieve the position of circuit breakers, status of medical gas and UPS.

Dimensions (mm)

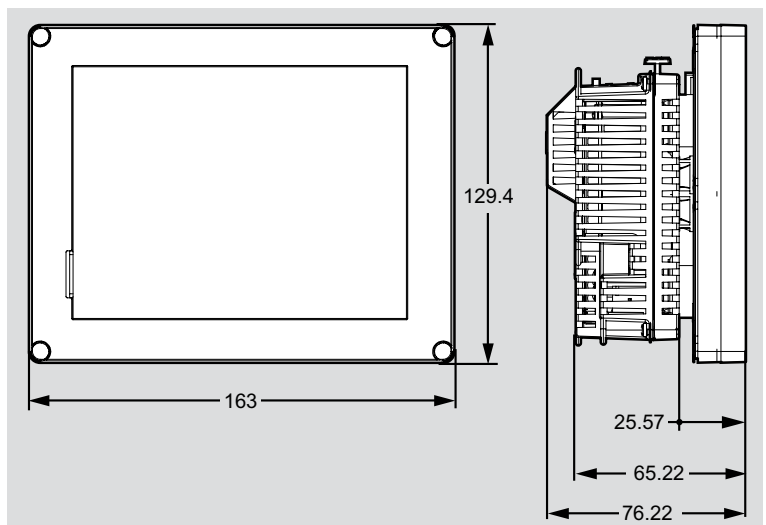

Operating Theater Display

Physical Description

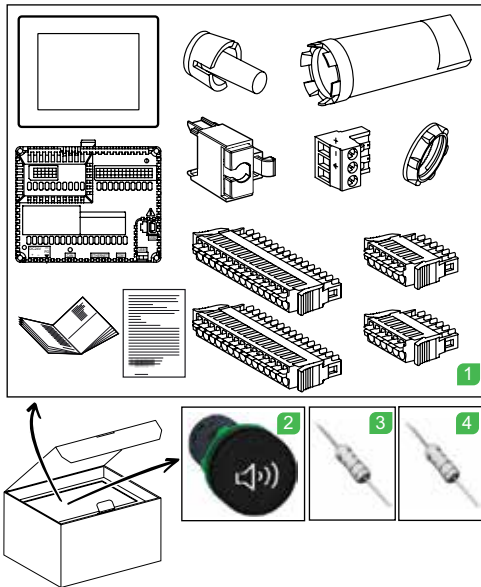

- 1 HMI controller
- 2 Buzzer
- 3 Resistor (39 kOhms, 2W)
- 4 Resistor (2 MOhms, 0,5W)

General characteristics

Commercial Name		Operating Theater Display
Product Performance		
Display	Resolution	320 x 240 pixels QVGA, 65k colors
	Display type	5,7 inch with backlit LED color TFT LCD
Display operation		Touch panel
Communication	Protocols	Modbus RS485, Modbus TCP/IP
	Ports	1 RJ45 port for RS485 1 RJ45 port for Ethernet TCP/IP 1 USB 2.0 type mini B port 1 USB 2.0 type A port
Mecanical characteristics		
Protection degree	Front	IP65
	Rear	IP20
Electrical characteristics		
Power Supply	Auxiliary Power Supply Voltage	24 V CC (20.4 à 28.8 V CC)
	Maximum Consumption	24W
Environment		
Temperature strength	For operation	0 °C to 50 °C
	For storage	-25 °C to +70 °C
Relative Humidity		85 %
Altitude max.		2000 m



ZX Impedance



Commercial reference

- 50159.

Standards & certifications

- IEC61010-1 Ed.2010
- UL 61010-1 Ed3.2012
- IEC61326-4 Ed.2012



Functions

The ZX is an earthing impedance, to be connected between an IT network (transformer neutral) and the ground.

- It prevents voltage variations that can cause damages to some devices present on the network (such as PLCs, modems, power supplies when they are nearby the transformer)
- It allows differential currents in the event of a fault to loop back through the transformer, and thus be seen by the main differential protection
- The use of ZX earthing impedance is not mandatory, but it is particularly recommended for small IT networks (limited length of cable).

Main features

- Combination of R, L, C components
- At 50Hz, its impedance is 1500 Ω
- At the injection frequency of a Vigilohm insulation monitor, its impedance is high and does not affect the Vigilohm measurements

Application

- Small ungrounded networks below 500 VAC
- Not compatible with healthcare and photovoltaic applications

Compatible products

- Compatible with the use of any Insulation Monitor
- To be connected in parallel with the Insulation Monitor and the Cardew

Connection

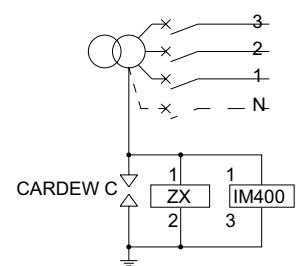
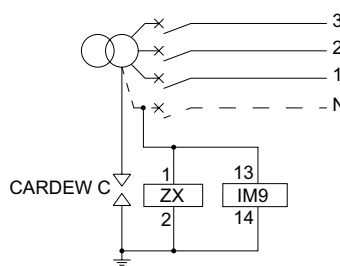
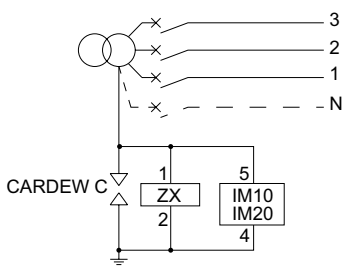

Dimensions (mm)

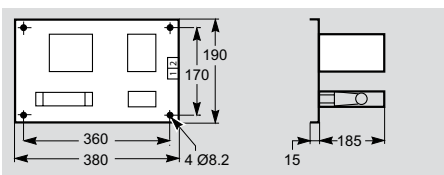

General characteristics

Commercial name	ZX Impedance
Type of network to be monitored	
AC Voltage range	0...500 V AC
Grounding arrangement	IT
Product Performances	
Impedance	1500 Ohm at 50Hz
Weight	1,75 kg
Mounting	Wall mounted, grid

Vigilohm P1N Plate Ground Adaptor



P1N Plate



Functions

- Used in combination with a Vigilohm IM400THR or IM400LTHR for monitoring the isolation of medium voltage IT networks
- Filters the AC signal and protects the IM400THR from network overvoltages
- Mandatory accessory

Compatible auxiliaries

- IM400THR and IM400LTHR
- Used in combination with voltage transformers

Physical Description

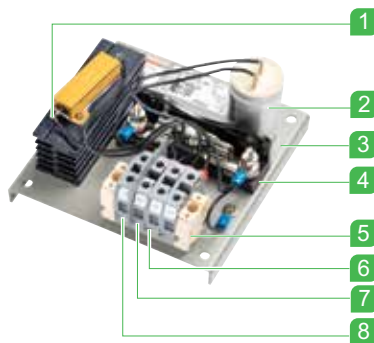

- 1 Filter resistor
- 2 Filter capacitor
- 3 Mounting plate
- 4 Gas discharge tube
- 5 Terminal block
- 6 Terminal 3 to ground
- 7 Terminal 2 to voltage transformer
- 8 Terminal 1 to IM400THR

Commercial reference

- 1460872.

Standards & certifications

- IEC61010-1 Ed.2010
- UL 61010-1 Ed3.2012
- IEC61326-4 Ed.2012



Examples of architectures

Three-phase network with accessible neutral

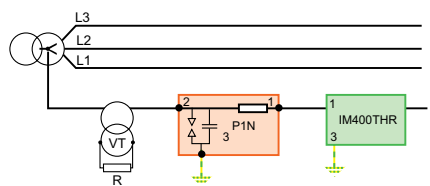

Three-phase network without neutral accessible

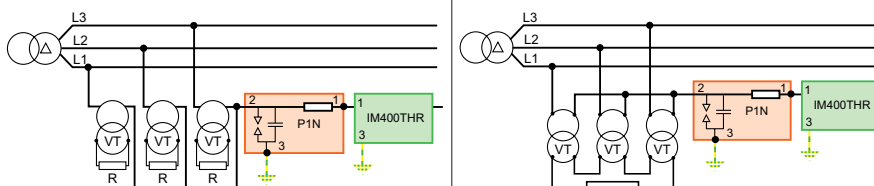

Dimensions

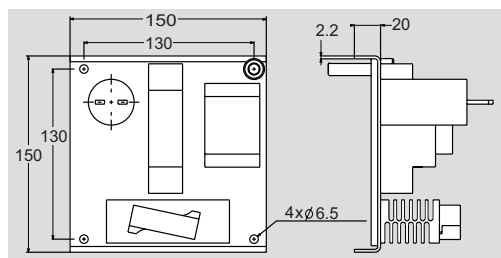

General characteristics

Commercial name		Ground Adaptor P1N
Type of network to be monitored		
AC (max phase to phase voltage)	IM Connected to neutral	< assigned voltage of the Voltage transformer
	IM Connected to phase	< assigned voltage of the Voltage transformer
DC (max line voltage)		not compatible
Grounding arrangement		IT / ungrounded medium voltage
Product Performances		
Weight		1kg
Mounting		Wall mounted
Environment		
Overvoltage category		300 V/OVC3 / 600 V/OVC2
Temperature strength	For operation	-25°C to +55°C
Altitude max.		3000m



Cardew C

Vigilohm Cardew C Surge limiter



Commercial reference

- 250 V Cardew C: 50170
- 440 V Cardew C: 50171
- 660 V Cardew C: 50172
- 1000 V Cardew C: 50183
- Cardew base: 50169

Standards & certifications

- IEC 60950
- NFC 63-150
- NFC 15-100
- Mandatory in some countries



Example of architecture

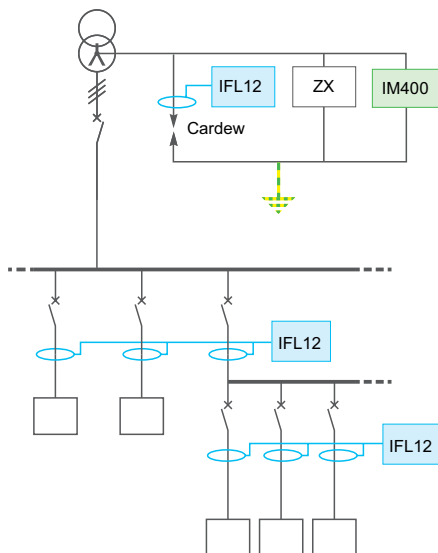

Functions

Surge limiters are used on IT networks and installed at the output of the MV/LV transformer.

They protect ungrounded networks from overvoltages, that can be due to:

- internal breakdown of the MV/LV transformer
- lightning strikes on the upstream MV network

These overvoltages could have serious consequences and damage devices connected to the grid. The cardew will allow high energy overvoltages to flow to the earth, hence protecting the downstream ungrounded network.

Main features

- Essential accessory to protect IT networks downstream of a MV/LV transformer
- Not required downstream of a LV/LV transformer
- Can withstand the short-circuit current of the transformer
- Consists of two conductive elements separated by an insulating film
- A high energy overvoltage will cause the internal insulating film to melt, allowing the overvoltage to be evacuated to the ground
- Once the internal insulating film has melted, it causes an insulation fault on the IT network, detected by the Insulation Monitor. The cartridge then needs to be replaced.

Compatible products

- It is recommended to monitor the cardew with an insulation fault locator such as IFL12; so that an insulation fault due to the cardew can be immediately identified, and its cartridge replaced.

Physical description

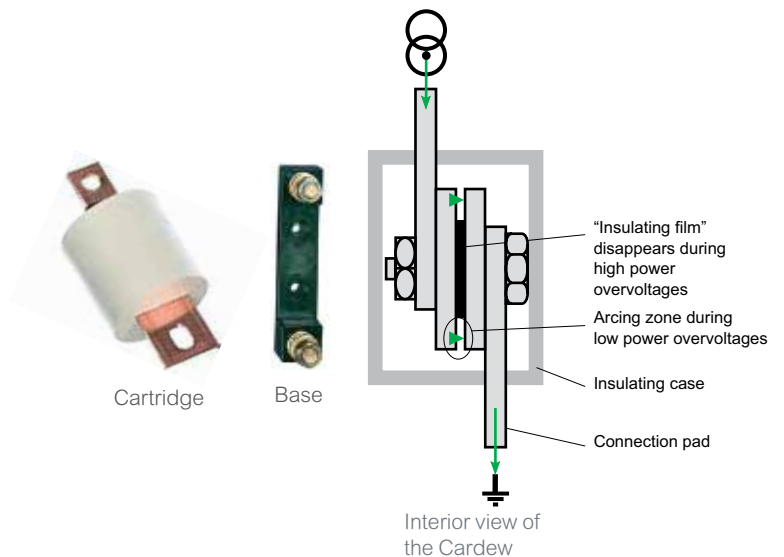

Dimensions

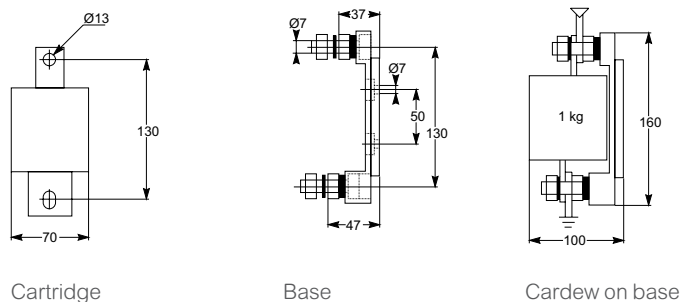

Connection

- It must be connected as close as possible to the MV/LV transformer between neutral and ground, or between a phase and ground if neutral is not accessible
- Specification of the connecting cable should be the following:
 - Sizing of cable or bar should be adapted to the transformer rating
 - Connecting conductor should be considered as a protective conductor (PE), the calculation of its cross sectional area should comply with standards, considering that the protection for this part of the installation is done by protective devices located upstream of the MV/LV transformer
 - According to IEC 364 standard, calculation formula of the size of the PE conductor is: $S = \sqrt{I^2 t / k}$ where S is the cross-sectional area of the PE conductor in mm², I is the fault current, t is the operating time of the protective device and k is a coefficient that depends on the metal and insulation material used for the conductor.

General characteristics

Commercial name		Cardew 250V	Cardew 440V	Cardew 660V	Cardew 1000V
Type of network to be monitored					
Max phase to phase voltage	Connected to neutral	380V	380 V < U ≤ 660 V	660 V < U ≤ 1000 V	1000 V < U ≤ 1560 V
	Connected to phase	220 V	220 V < U ≤ 380 V	380 V < U ≤ 660 V	660 V < U ≤ 1000 V
Ui arcing voltage		400 V < Ui ≤ 750 V	700 V < Ui ≤ 1100 V	1100 V < Ui ≤ 1600 V	1600 V < Ui ≤ 2400 V
Product Performances					
Internal impedance		10 [^] 10 Ω			
Non-arcing voltage at 50 Hz		< 1.6 x nominal voltage			
Arcing voltage at 50Hz		> 3 x nominal voltage	> 2.5 x nominal voltage		
Maximum current after arcing		40 kA/0.2 s			
Mounting		Cable or bar with a size adapted to the transformer rating			
Weight		1kg			
Environment					
Temperature strength	For operation	-5°C to +40°C			
	For storage	-25°C to +70°C			

To know more :
Refer to the technical publication: The IT earthing system (unearthed neutral) in LV)



IT Medical Transformer - Europe Range



Functions

Single phase and three phase transformers for medical locations.

Application

- For medical rooms requiring ungrounded network as per IEC 60364-7-710.
- Compliant with NF EN 61558-2-15 medical use edition 2001-10: leakage current between the enclosure and the earth limited to 3.5 mA, limitation of the voltage assigned to the secondary between phases at 250 V – 50 Hz.

Compatible auxiliaries

- Insulation Monitoring Devices: IM10-H, IM15H, IM20-H, IFL12H.
- Overheat and overload monitoring can be done by IM15H or IM20-H.

Dimensions

Single-phase transformers

without cover - IP00

with cover - IP21, IK07

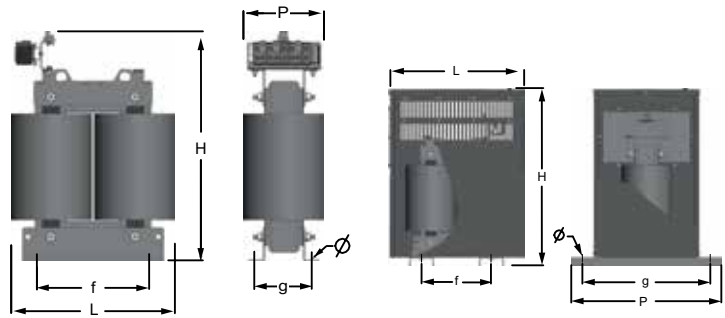

Three-phase transformers

without cover - IP00

with cover - IP21, IK07

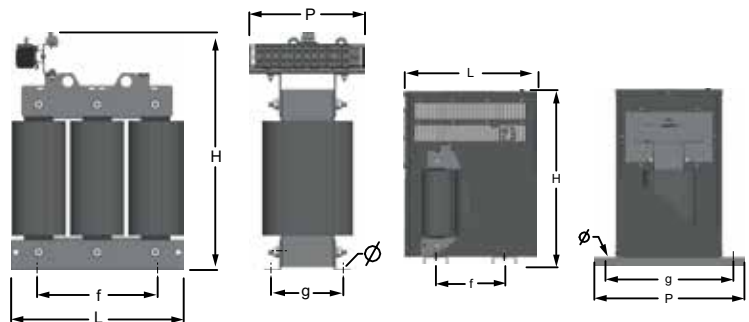

Commercial reference

- IMDTR6S00
- IMDTR8S00
- IMDTR10S00
- IMDTR6S21
- IMDTR8S21
- IMDTR10S21
- IMDTR6T00
- IMDTR8T00
- IMDTR10T00
- IMDTR6T21
- IMDTR8T21
- IMDTR10T21

Standards and certifications

- IEC 60364-7-710
- NF EN 61558-2-15



Note

Thermal protection, against overload, is performed by the temperature sensors embedded in the transformers. A magnetic protection can be used instead of a magnetothermal one for the upstream protection of the transformer. This solution allows to have continuity of service in case of overload, as the technician can correct the issue without having an interruption of power. These transformers have an inrush current up to 12 In and the MA curve is the most appropriate.

Protections for the Transformers

	Transfo 6.3kVA 1-phase	Transfo 8kVA 1-phase	Transfo 10kVA 1-phase	Transfo 6.3kVA 3-phase	Transfo 8kVA 3-phase	Transfo 10kVA 3-phase
Magnetic CB setting MA curve	32 A	40 A	40 A	10 A	16 A	16 A

IT Medical Transformer - Europe Range

General characteristics

Commercial name	IMDTR6S00	IMDTR6S21	IMDTR8S00	IMDTR8S21	IMDTR10S00	IMDTR10S21
Product Performances						
Number of phases	Single-phase					
Rated Power	6.3 kVA		8 kVA		10 kVA	
Voltage Ratio	230 V / 115 V - 230V with load					
U _{max} in the secondary	250V					
Rated frequency	50 / 60 Hz					
Short circuit voltage	< 3%					
Magnetising current	< 3%					
In-rush Current	< 12 I _n					
Leakage Current between enclosure and earth	< 3.5 mA					
Leakage Current between secondary and earth	< 0.5 mA					
Insulation Level	1.1 kV					
Equipped with heat protection	Yes - Thermostatic plug per column					
Mechanical Characteristics						
Protection degree	IP00	IP21 IK07	IP00	IP21 IK07	IP00	IP21 IK07
Weight (kg)	44	57	47	60	51	64
Heating Class	F					
Insulation Class	H					
Dimension- Length L (mm)	335	490	345	490	365	490
Dimension- Fixing f x g (mm)	250 x 125	250 x 460	250 x 125	250 x 460	250 x 125	250 x 460
Dimension- Height H (mm)	500	630	500	630	510	630
Dimension- Depth P	165	540	185	540	180	540
Dimension- Ø (mm)	11	13	11	13	11	13
Environment						
Temperature - For Storage	-25°C...50°C					
Temperature - For Operation	-25°C...40°C					
Humidity	< 93%					
Use Category	Indoor					
Altitude	1000 m					

Commercial name	IMDTR6T00	IMDTR6T21	IMDTR8T00	IMDTR8T21	IMDTR10T00	IMDTR10T21
Product Performances						
Number of phases	Three-phase					
Rated Power	6.3 kVA		8 kVA		10 kVA	
Voltage Ratio	400 V / 230 V with load					
U _{max} in the secondary	250V					
Rated frequency	50 / 60 Hz					
Short circuit voltage	< 3%					
Magnetising current	< 3%					
In-rush Current	< 12 I _n					
Leakage Current between enclosure and earth	< 3.5 mA					
Leakage Current between secondary and earth	< 0.5 mA					
Insulation Level	1.1 kV					
Equipped with heat protection	Yes - Thermostatic plug per column					
Mechanical Characteristics						
Protection Degree	IP00	IP21 IK07	IP00	IP21 IK07	IP00	IP21 IK07
Weight (kg)	49	61	66	78	77	90
Heating Class	F					
Insulation Class	H					
Dimension- Length L (mm)	335	480	325	480	350	480
Dimension- Fixing f x g (mm)	250 x 150	250 x 460	250 x 150	250 x 460	250 x 150	250 x 460
Dimension- Height H (mm)	435	630	475	630	495	630
Dimension- Depth P	240	540	240	540	240	540
Dimension- Ø (mm)	11	13	11	13	11	13
Environment						
Temperature - For Storage	-25°C...50°C					
Temperature - For Operation	-25°C...40°C					
Humidity	< 93%					
Use Category	Indoor					
Altitude	1000 m					

IT Medical Transformers - Asia Range



Functions

Single phase isolation transformers for medical locations.

Application

- For medical rooms requiring ungrounded network as per IEC 60364-7-710.

Compatible auxiliaries

- Insulation Monitoring Devices: IM10-H, IM15H, IM20-H, IFL12H.
- Overheat and overload monitoring can be done by IM15H or IM20-H.

Dimensions

Commercial reference

- IMD-IT-S63-H
- IMD-IT-S80-H
- IMD-IT-S100-H

Standards & certifications

- IEC 60364-7-710
- IEC 61558-2-15: 2011
- GB 19212.1
- GB 19212.16-2005

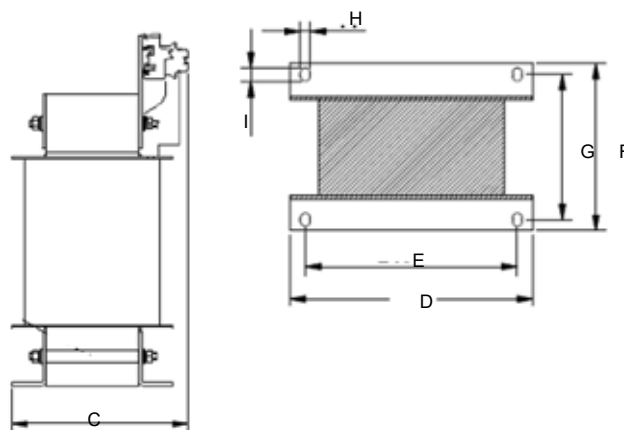
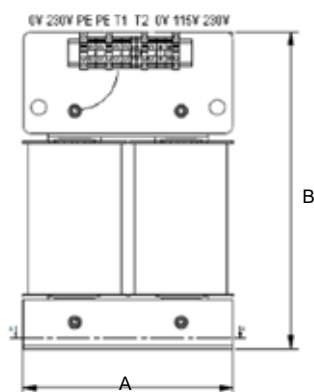

IT Medical Transformers - Asia Range

General characteristics

Commercial name	Single Phase, Isolated Transformer, 6.3KVA	Single Phase, Isolated Transformer, 8KVA	Single Phase, Isolated Transformer, 10KVA
Product Performances			
Rated Power	6.3 kVA	8 kVA	10 kVA
Rated supply voltage	230V +or- 10%		
Rated output voltage	230V AC / 115V AC		
Rated output current	27.4 A	34.7 A	43.5 A
Rated frequency	50 / 60 Hz +or- 3Hz		
Efficiency	> 96 %		
Short circuit voltage	< 3 %		
No-load losses	65 W max	75 W max	85 W max
Winding losses	150 W max (25°C)	200 W max (25°C)	250 W max (25°C)
In-rush Current	< 12 Ip		
Leakage Current between primary and bracket	< 3,5 mA (when input 230V/50Hz)		
Leakage Current between primary and secondary	< 3,5 mA (when input 230V/50Hz)		
Noise	< 50 dB at 1 meter		
Mechanical Characteristics			
Protection Degree	IP00		
Weight	72 kg	79 kg	97 kg
Cooling	AN		
Insulation Class	H		
Dimension - A	280 mm max		
Dimension - B	427 mm max		
Dimension - C	210 mm max	225 mm max	255 mm max
Dimension - D	275 mm		
Dimension - E	240 mm +or- 2		
Dimension - F	190 mm	205 mm	235 mm
Dimension - G	165 mm +or- 3	180mm +or- 3	210 mm +or- 3
Dimension - H	11 mm		
Dimension - I	15 mm		
Environment			
Temperature - For Storage	-25°C to 60°C		
Temperature - For Operation	0°C to 40°C		
Humidity	20 to 80% RH without dew		
Use Category	Indoor		
Altitude	<2000m		



Vigilohm

Vigilohm IM20-1700, IM400-1700, IM400-1700C, PHT1000 and IM400VA2 Voltage Adaptors



IM20-1700, IM400-1700, IM400-1700C.



PHT1000.



IM400VA2.

Functions

Vigilohm voltage adaptors allow to monitor insulation level of networks with a higher voltage level than what the Insulation Monitoring Devices can natively stand. They are connected between the network and the IMD, and lower the voltage level seen by the IMD.

Applications

- Industrial sites (IM20-1700, IM400-1700, IM400-1700C)
- Photovoltaic sites (IM400-1700C, IM400VA2)
- Sites with harsh environment (IM400-1700C, IM400VA2 are conformally coated).

Compatible products

- Insulation Monitors: IM20, IM400, IM400L, IM400C – refer to General Characteristics table
- PHT1000 is compatible with the use of Insulation Fault Locators: IFL12 range (except IFL12H), and former ranges XD301, XD312, XL3xx, XML3xx

Dimensions (mm)

IM20-1700

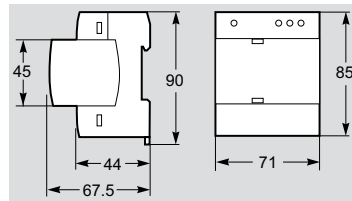

IM400-1700, IM400-1700C

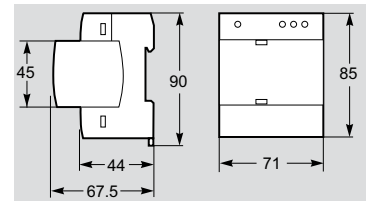

PHT1000

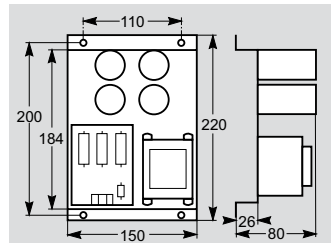

IM400VA2

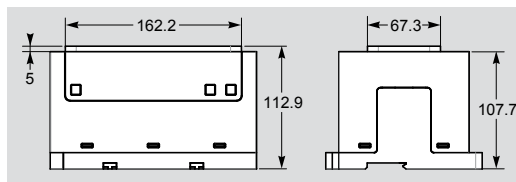
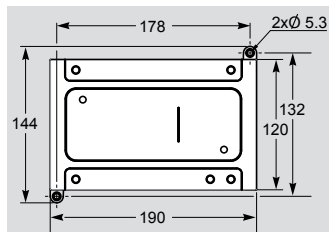

Commercial reference

- IM20-1700: IMD-IM20-1700
- IM400-1700: IMD-IM400-1700
- IM400-1700C: IMD-IM400-1700C
- IM400VA2: IMD-IM400VA2
- PHT1000: 50248.

Standards & certifications

- IEC 61010-1 Ed.2010
- UL 61010-1 Ed.3.2012
- IEC 61326-4 Ed.2012



Voltage Adaptors

Installation

IM400-1700 / IM400-1700C	PHT1000	IM400VA2
Connection to network: to neutral or to a phase or to a polarity	Connection to network: to neutral or to a phase or to a polarity	Connection to network: two points of connection, to neutral + a phase or to two phases or to two polarities
IM20-1700		
Connection to network: to neutral or to a phase or to a polarity		

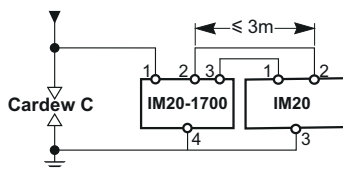

General characteristics

Commercial name	IM20-1700	IM400-1700	IM400-1700C	PHT1000	IM400VA2
Type of network to monitor					
Type of application	Industrial ungrounded networks		Industrial and Photovoltaic ungrounded networks	Industrial ungrounded networks	Photovoltaic ungrounded networks
AC Voltage range (max ph-ph voltage)	<1700VAC (connection to neutral) or <1000VAC (connection to a phase)				<2600VAC (connection to neutral) or <1500VAC (connection to a phase)
DC Voltage range	<1000VDC			<1200VDC	<1500VDC
Compatibility with Insulation Monitor	IM20	IM400, IM400L	IM400C	IM400, IM400L, IM400C	IM400C
Maximum distance to insulation monitor	3 meters				
Compatibility with Insulation Fault Locator	No			IFL12 series, XD301, XD312, XL3xx	No
Maximum network capacitance	150µF	500µF	500µF (if not used in Photovoltaic application) 2000µF (Photovoltaic)	500µF	5500µF
Product Performances					
Internal impedance	400 kΩ			660kOhms	564 kΩ
Mounting	DIN rail			Mounting plate or in a box	DIN rail and mounting plate
Weight	0.2 kg			2 kg	0.75 kg
Environment					
Conformal coating	No	No	Yes	No	Yes



ZX Impedance

Vigilohm ZX Plate Earthing Impedance



Commercial reference

- 50159.

Standards & certifications

- IEC61010-1 Ed.2010
- UL 61010-1 Ed3.2012
- IEC61326-4 Ed.2012



Functions

The ZX is an earthing impedance, to be connected between an IT network (transformer neutral) and the ground.

- It prevents voltage variations that can cause damages to some devices present on the network (such as PLCs, modems, power supplies when they are nearby the transformer)
- It allows differential currents in the event of a fault to loop back through the transformer, and thus be seen by the main differential protection
- The use of ZX earthing impedance is not mandatory, but it is particularly recommended for small IT networks (limited length of cable).

Main features

- Combination of R, L, C components
- At 50Hz, its impedance is 1500 Ω
- At the injection frequency of a Vigilohm insulation monitor, its impedance is high and does not affect the Vigilohm measurements

Application

- Small ungrounded networks below 500 VAC
- Not compatible with healthcare and photovoltaic applications

Compatible products

- Compatible with the use of any Insulation Monitor
- To be connected in parallel with the Insulation Monitor and the Cardew

Connection

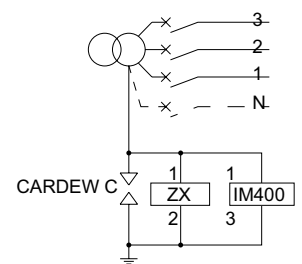
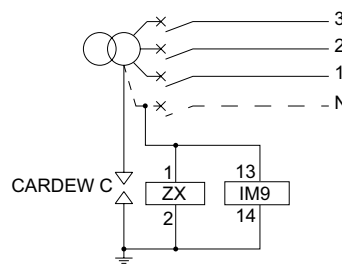
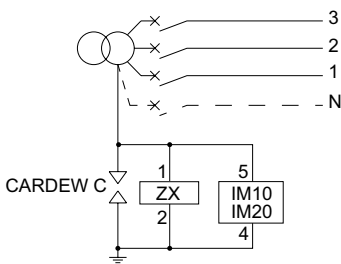

Dimensions (mm)

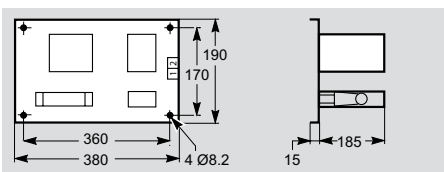

General characteristics

Commercial name	ZX Impedance
Type of network to be monitored	
AC Voltage range	0...500 V AC
Grounding arrangement	IT
Product Performances	
Impedance	1500 Ohm at 50Hz
Weight	1,75 kg
Mounting	Wall mounted, grid

Vigilohm P1N Plate Ground Adaptor



P1N Plate



Functions

- Used in combination with a Vigilohm IM400THR or IM400LTHR for monitoring the isolation of medium voltage IT networks
- Filters the AC signal and protects the IM400THR from network overvoltages
- Mandatory accessory

Compatible auxiliaries

- IM400THR and IM400LTHR
- Used in combination with voltage transformers

Commercial reference

- 1460872.

Standards & certifications

- IEC61010-1 Ed.2010
- UL 61010-1 Ed3.2012
- IEC61326-4 Ed.2012



Physical Description

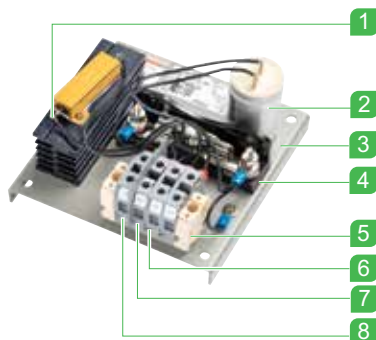

- 1 Filter resistor
- 2 Filter capacitor
- 3 Mounting plate
- 4 Gas discharge tube
- 5 Terminal block
- 6 Terminal 3 to ground
- 7 Terminal 2 to voltage transformer
- 8 Terminal 1 to IM400THR

Examples of architectures

Three-phase network with accessible neutral

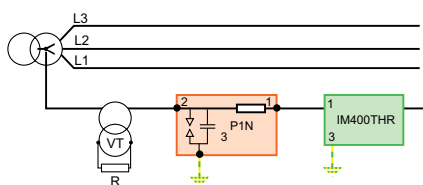

Three-phase network without neutral accessible

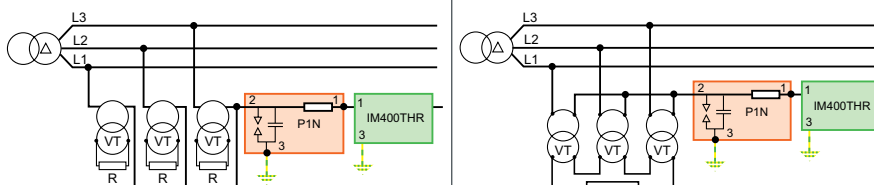

Dimensions

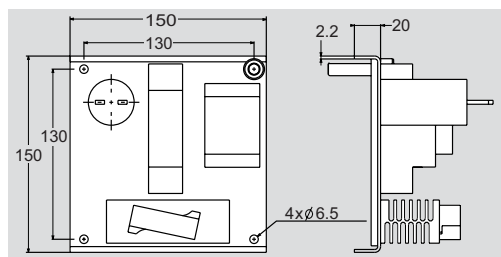

General characteristics

Commercial name		Ground Adaptor P1N
Type of network to be monitored		
AC (max phase to phase voltage)	IM Connected to neutral	< assigned voltage of the Voltage transformer
	IM Connected to phase	< assigned voltage of the Voltage transformer
DC (max line voltage)		not compatible
Grounding arrangement		IT / ungrounded medium voltage
Product Performances		
Weight		1kg
Mounting		Wall mounted
Environment		
Overvoltage category		300 V/OVC3 / 600 V/OVC2
Temperature strength	For operation	-25°C to +55°C
Altitude max.		3000m

Life Is On



<https://sid1.hu/>

Schneider Electric Industries SAS

35, rue Joseph Monier
CS 30323
92506 Rueil Malmaison Cedex
France

RCS Nanterre 954 503 439
Capital social 896 313 776 €
www.se.com

03-19

© 2019- Schneider Electric. All Rights Reserved.
All trademarks are owned by Schneider Electric Industries SAS or its affiliated companies.
VIGILOHM CATALOG
Document reference: PLS3ED310020EN